

DESCRIPTION

Solenoid pilot 2 way normally closed. Tube Ø13.

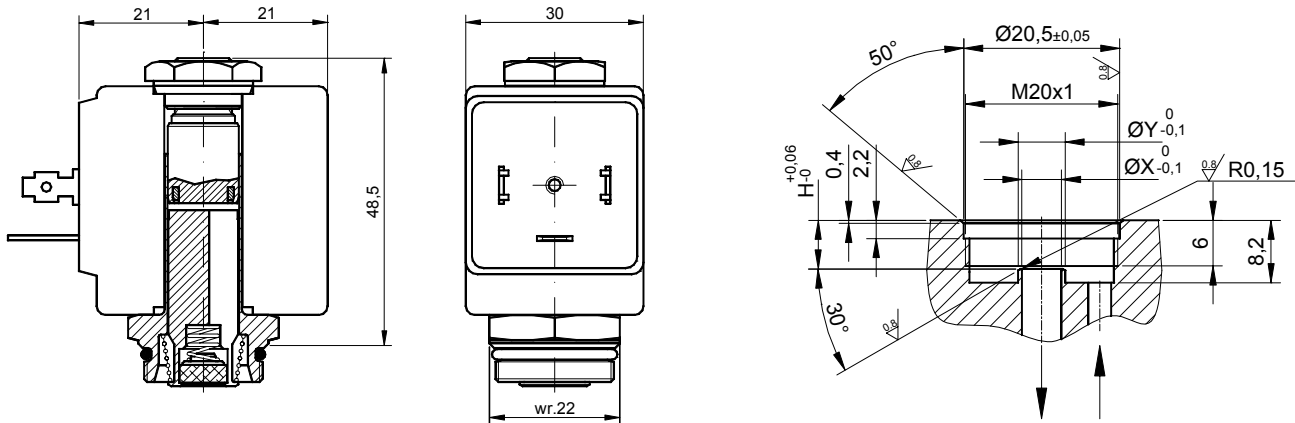

Available version for X=Ø6.4mm

CODE S.Steel Tube	Ø X mm	H mm	ØY mm	Differential pressure bar			Nominal power			Coil		Seal	Temp. range °C		
				Min	Max		AC Inrush	VA Holding	DC Watt	Series	Width				
					AC	DC									
E610.....	1.5	6.2	4.2	0	30	26	20	15	10	2	30	NBR=B	-10 +90		
	2	6.2	4.2	0	22	20	20	15	10	2	30			EPDM=E	<+140
	2.5	6.2	4.2	0	16	14	20	15	10	2	30	FPM=V	-10 +130		
	3.5	6.2	6.2	0	10	8	20	15	10	2	30				
	4.5	6.4	6.2	0	6.5	3.5	20	15	10	2	30				
5.2	6.4	6.2	0	4	1.8	20	15	10	2	30					

DESCRIPTION

Solenoid pilot 2 way normally open. Tube Ø13.

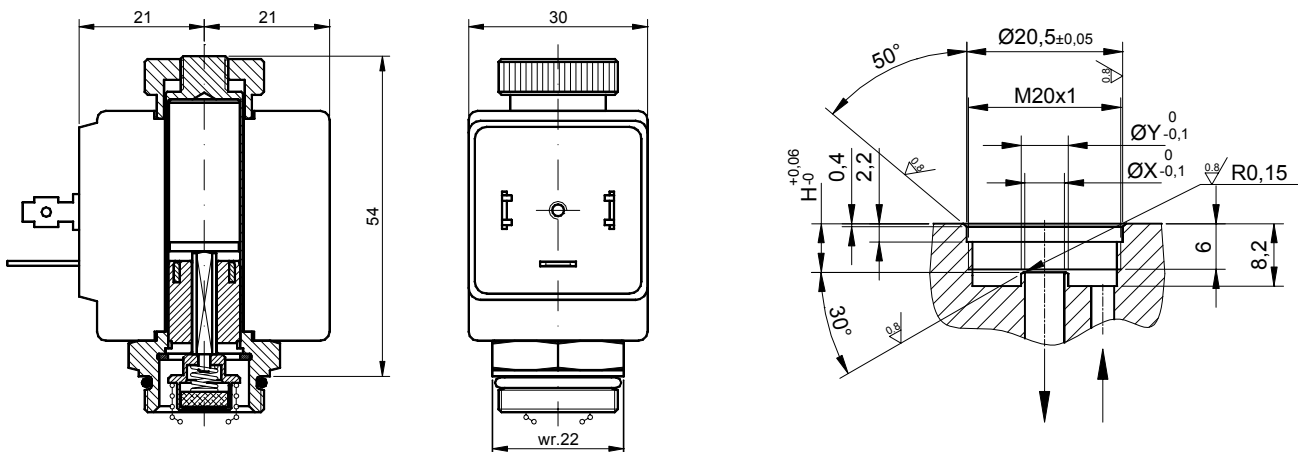

CODE		Ø X mm	H mm	ØY mm	Differential pressure bar			Nominal power			Coil		Seal	Temp. range °C		
S.Steel Tube	Brass Tube				Min	Max		AC Inrush	VA Holding	DC Watt	Series	Width				
						AC	DC									
E620	E622	1.5	6.2	4.2	0	23	23	20	15	10	2	30	NBR=B	-10 +90		
		2	6.2	4.2	0	17	17	20	15	10	2	30			EPDM=E	<+140
		2.5	6.2	4.2	0	12	12	20	15	10	2	30	FPM=V	-10 +130		
		3.5	6.2	6.2	0	7	4 ③	20	15	10	2	30				
		4.5	6.4	6.2	0	4.5	3 ③	20	15	10	2	30				
5.2	6.4	6.2	0	3	2.2 ③	20	15	10	2	30						

③ Only for the DC on the orifices Ø 3,5 - 4,5 - 5,2 the code is D620 or D622

ØX must be specified in the order

DESCRIPTION

Solenoid pilot 3 way normally closed. Tube Ø13.

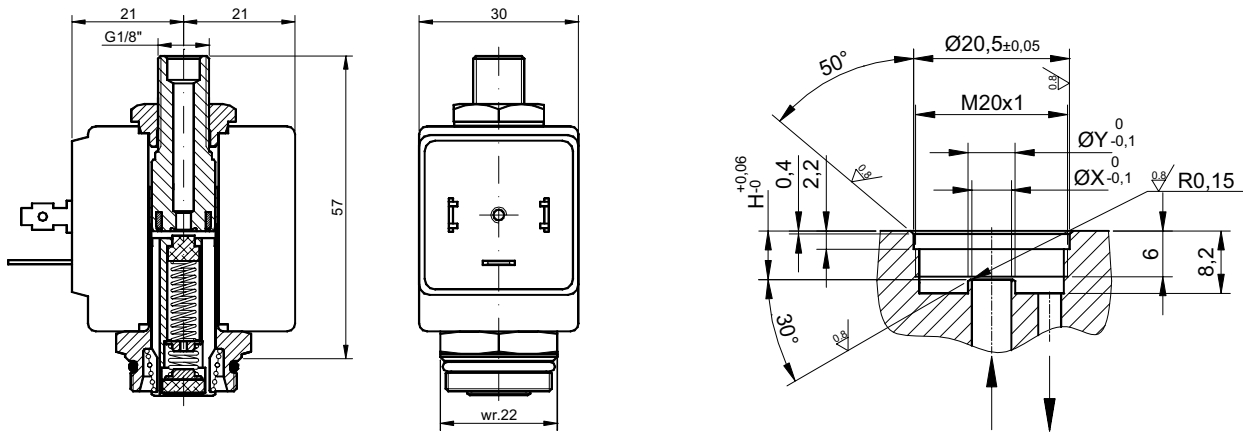

CODE S.Steel Tube	Ø X mm	H mm	Ø exh. mm	ØY mm	Differential pressure bar			Nominal power			Coil		Seal	Temp. range °C
					Min	Max		AC Inrush	VA Holding	DC Watt	Series	Width		
						AC	DC							
E630	1.5	6.2	2.4	4.2	0	20	20	20	15	10	2	30	NBR=B	-10 +90
	2	6.2	2.4	4.2	0	13	13	20	15	10	2	30	EPDM=E	<140
	2.5	6.2	2.4	4.2	4.2	0	10	10	20	15	10	2	30	FPM=V