

# HDM + MULTI-POLE CONNECTION

HDMs are the ideal solution for those requiring the unbeatable performance, flexibility and modularity of Multimach valves combined with sturdy mechanics and a high degree of protection against external agents. Each valve is enclosed in a reinforced technopolymer protective shell that acts as a shock-absorber and prevents the infiltration of dirt. The class of protection is IP65.

The smooth, rounded design makes HDMs ideal for applications requiring frequent washing without the deposit of residues. All the pneumatic connections are on one side, with built-in push-in fittings. The user interface is on another side so that the fitter and the service engineer have everything at hand.

Flexibility is total: there are 1-16 valves, input and output terminals for pipes of different sizes and intermediate modules for separate inputs and outputs. One very important new feature is that valves of different capacities can be mounted as required. Three different valve sizes can be combined at will. This means a valve can be replaced at any time by another one offering a different performance. It only takes a few seconds to replace or add a valve. To do this, merely loosen the two grub screws fixing the valve to the adjacent ones. Since the electrical signal is relayed from one valve to the next by means of gold-plated contacts connected to an electronic board, the electrical connections are entirely automatic.

The ratio of the HDM's flow rate to its dimensions is unrivalled – miniaturisation and efficiency have reached a peak.



TECHNICAL DATA						
Valve port connections		Ø 4,6,8,10 mm automatic fitting for ports 2 and 4 / power supply port for Ø10 or Ø 12 mm automatic fitting / 3/8 thread for exhaust port, M5 thread for exhaust pilot port				
Connection on the end-plate for the supply of pilots		Automatic fitting Ø 4 mm				
Maximum number of pilots		16				
Maximum number of valves		16 (same as the max. no. of pilots)				
Operating temperature range	°C	-10 to +60				
Fluid		Filtered air without lubrication; lubrication, if used, must be continuous				
Pressure range	bar	X (pilot supply)		1-11 (valve supply)		
	Terminal 1-1	3 to 7		vacuum at 10		
	Terminal 1			3 to 7		
Voltage range		24VDC ± 10%				
Power	W	0.9				
Control		PNP or NPN				
Insulation class		F155				
Degree of protection		IP65 (with conveyed exhaust)				
Solenoid rating		100% ED				
Flow rate at 6.3 bar ΔP 1 bar	Nl/min	11.5 mm Ø 4	11.5 mm Ø 6	14 mm Ø 8	23 mm Ø 8	23 mm Ø 10
	version 5/2 and 3/2	200	500	650	1000	1200
	version 5/3	200	300	300	500	500
TRA/TRR 2x3/2 monostable at 6 bar	ms	8 / 45			8 / 60	
TRA/TRR 5/2 monostable at 6 bar	ms	8 / 33			9 / 60	
TRA/TRR 5/2 bistable at 6 bar	ms	20 / 20			8 / 8	
TRA/TRR 5/3 cc monostable at 6 bar	ms	20 / 20			15 / 15	
Note on use		Insert the pipes in the fittings, before passing air through the valves, otherwise the basket may be pulled out of its seat by the flow of air.				
Compatibility with oils		See <b>chapter Z1</b>				

## COMPONENTS

- ① Exhaust - Solenoid pilot 82/84
- ② Valve supply - port 1
- ③ Threaded connection of exhausts 3/5
- ④ Valve supply - port 11
- ⑤ Electrical control supply X
- ⑥ Blind end-plate or right end-plate 1-11
- ⑦ Screw for valve wall-mounting
- ⑧ Utility port for pipe Ø 4, 6, 8 or 10 mm
- ⑪ Manual control
- ⑫ LED (LED on, solenoid valve energised)
- ⑬ Pneumatic symbol
- ⑭ Identification of the monostable or bistable manual control
- ⑮ Valve ordering code
- ⑯ Valve identification code
- ⑰ Blank space for valve number

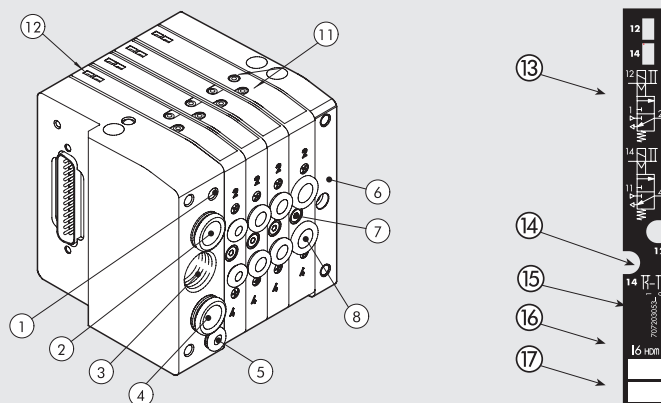

## THE MULTIMACH WORLD: FLEXIBILITY

The numbers permit rapid identification of the function and assembly position of the single elements represented as follows.

Refer to page B2.136 for valves, intermediates elements and common accessories.

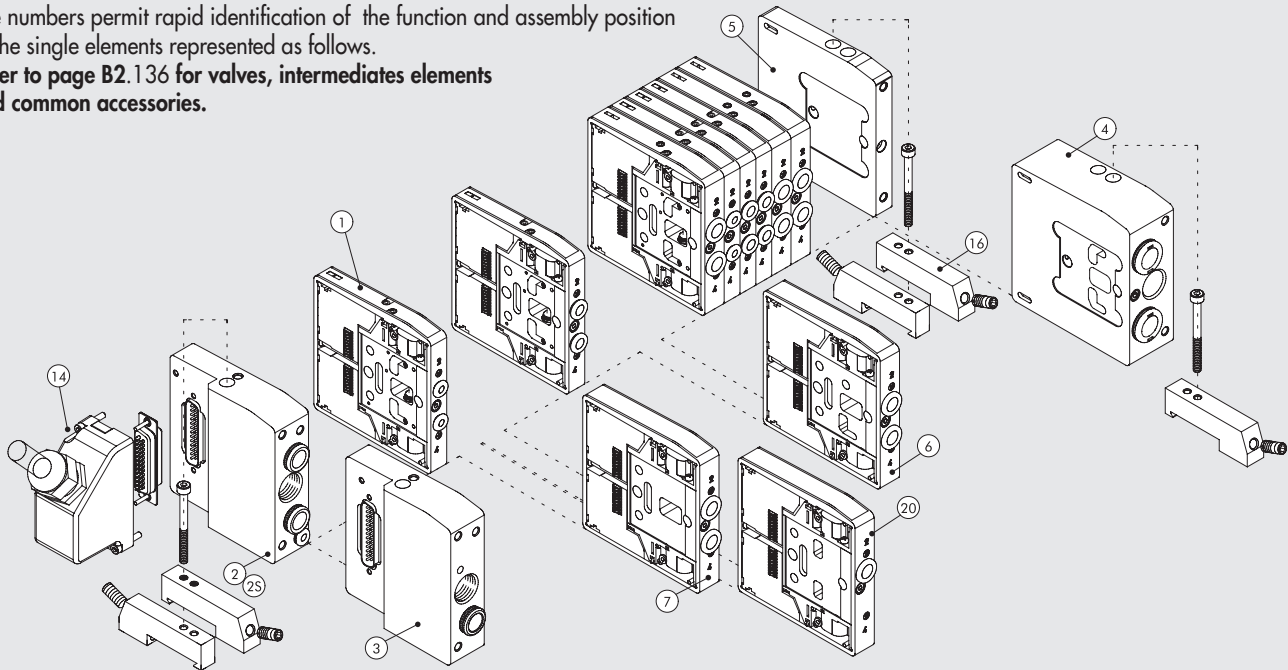

## FIXING THE BASE

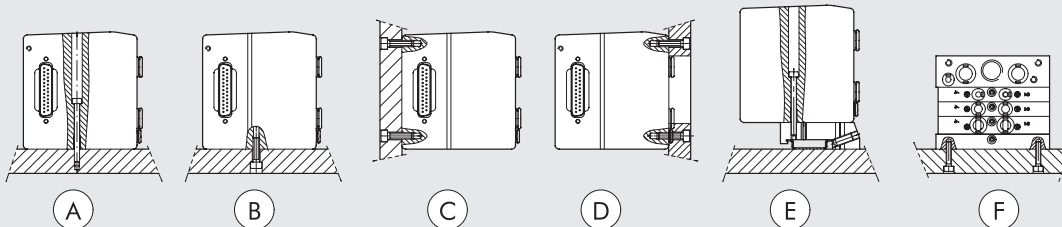

- Ⓐ Fixing from above using the 1 or 1-11 input terminal and the blind terminal.  
 Ⓑ Ⓒ Fixing from above using the 1 or 1-11 input terminal and the blind terminal, using the M5 threads on the bottom and the rear of the terminals.  
 Ⓓ Fixing from above using the 1 or 1-11 input terminal and the blind terminal, using the M5 threads on the front of the terminals.  
 An opening for the pipes is made in the plate.  
 Ⓔ Fixing on the DIN bar with end-plate 1 or 1-11 and blind and plate, using the push-in bracket code 0227301600.  
 Ⓕ Lateral fixing using the blind terminal, and its the M4 threads on the side lateral.

**Note: The sole fixing admitted is the one showed.**

## SYNOPTIC, SIZES AND VERSIONS

H D M VALVE	2 INPUT END-PLATE	8 ELECTRICAL BASE	M MANUAL TYPE	16 - W 8 - W 6 - O 4 - L 8 - 5 TYPE OF VALVE	1 4 - 1 6 FURTHER DETAILS
Heavy duty Multimach IP65	2 End-plate 1-11 pipe Ø 10 3 End-plate 1 pipe Ø 10 2S End-plate 1-11 pipe Ø 12	8 D-Sub 25 wire	M Monostable manual control B Bistable manual control	I n° 2 3/2 NC W n° 2 3/2 NO L 3/2 NO + 3/2 NC V 5/2 monostable K 5/2 bistable O 5/3 monostable *F 5/2 monostable 4 right-end-plate 1-11 pipe Ø12 5 blind end-plate 6 Passing-intermede 7 Blind intermediate 20 Exhaust section 4 Cartridge 4 6 Cartridge 6 8 Cartridge 8 - 14 mm 8S Cartridge 8 - 23 mm 10 Cartridge 10	14 IP65 25-wire shell 16 n° 2 brackets for DIN bar

\* Uses a single PIN (like the V) and occupies 2 signals.

WIRING DIAGRAM

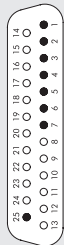
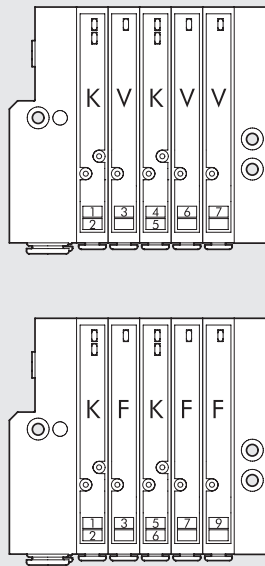

PNP - Com (-)  
NPN - Com (+)

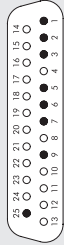

NOTE: The type F monostable valve uses one PIN only (like the V) but occupies 2 signals.

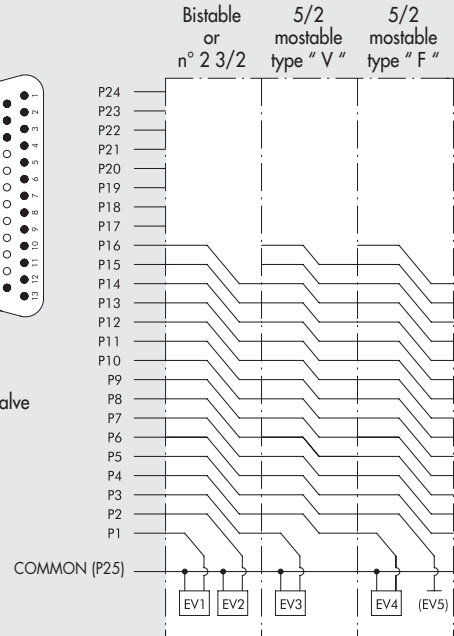

② END-PLATE 1-11-25D - PIPE Ø10

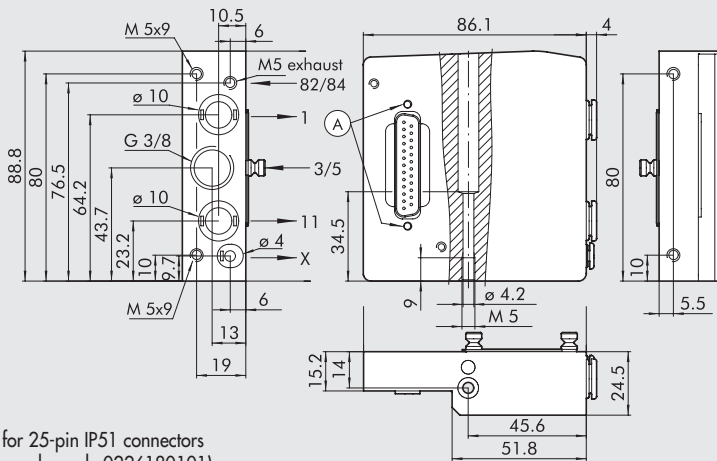

Ⓐ = Holes for 25-pin IP51 connectors (for example, code 0226180101)

Code	Description	Weight [g]
0227301200	End-plate HDM 1-11-25D Ø10	370

This end-plate allows for supplies to be differentiated

- Port 2
- Port 4
- Pilot supply

②S END-PLATE 1-11-25D - PIPE Ø12

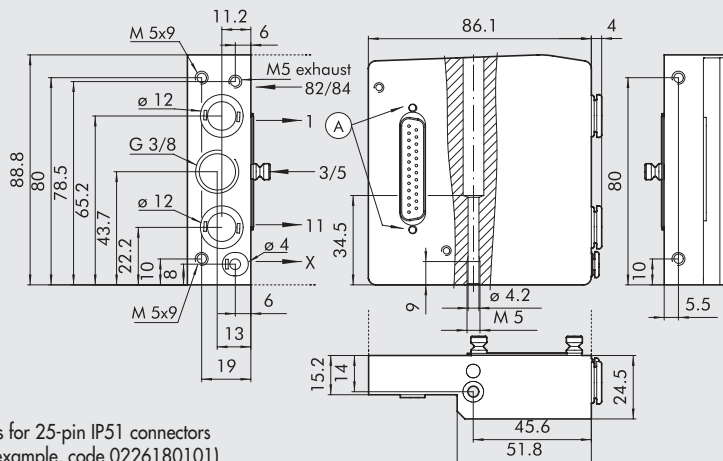

Ⓐ = Holes for 25-pin IP51 connectors (for example, code 0226180101)

Code	Description	Weight [g]
0227301220	End-plate HDM 1-11-25D Ø12	370

This end-plate allows for supplies to be differentiated

- Port 2
- Port 4
- Pilot supply



# HDM + AS-Interface

The HDM+AS-Interface system has been designed in such a way that the pneumatic input terminal contains all the electronics, signals and AS-I connectors. It is a very compact and sturdy system where everything is housed in a thick casing aluminium to protect the delicate components against impact. The valves and accessories are HDM standard, which means that you only need to replace the input terminal to convert the valve island with multiple connector into an AS-I island. All the advantages of the HDM system can be exploited: the possibility of mounting valves of different size, with fittings for pipes 4, 6, 8 or 10; the insertion of intermediate modules with separate power supply or outlets; aluminium valves with chemical nickel plating enclosed in a protective casing in reinforced technopolymer, with an index of protection IP65. The arrangement of the functions continues the traditional optimisation of the HDMs: the user interface of the valves and bus all on one side, so that the fitter and service engineer have everything within easy reach: all compressed air connections on the other side; the connectors for AS-I cables on the opposite side longitudinally, so that several valve islands can be arranged in line, fixed on a DIN bar.

There are many AS-I terminal variants to meet all possible requirements:

- with 1 node, for controlling up to 4 valve solenoid pilots;
- with 2 nodes, for controlling up to 8 solenoid pilots;
- with 1 node for output and input for controlling up to 4 solenoid pilots and receiving up to 4 input signals. The input connectors are M8 or M12;
- with 2 nodes for output and input for controlling up to 8 solenoid pilots and receiving up to 8 input signals with M8 connectors;
- power supply with the AS-I yellow cable only;
- power supply with two cables: the yellow AS-I cable and the black power supply cable.
- traditional V.2.1 addressing or extended AB V.3.0 address for an increase in the node numbers which can be connected up to 62 and for a better diagnostics

**Note: if you use valves 8S type or 10 exploiting their flow capacity it is necessary that the feeding pressure is at least 6 bar (to avoid the pressure to decrease too much on the pilots).**

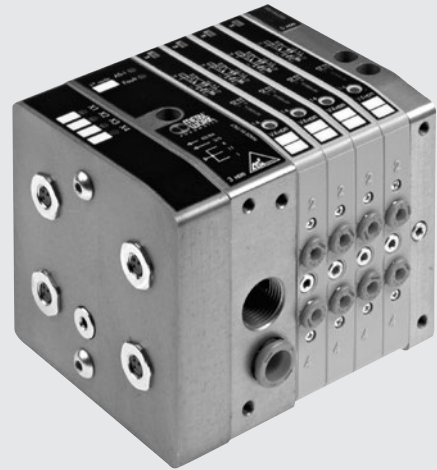

TECHNICAL DATA						
Valve port connections		Ø 4,6,8,10 mm automatic fitting for ports 2 and 4 / power supply port for Ø10 or 12* automatic fitting / 3/8 thread for exhaust port, M5 thread for exhaust pilot port				
Maximum number of pilots		Terminal with 1 node = 4 / terminal with 2 node = 8				
Maximum number of valves		Terminal with 1 node = 4 (same as the max. no. of pilots) / terminal with 2 node = 8 (same as the max. no. of pilots)				
Operating temperature range	°C	-10 to +60				
Fluid		Filtered air without lubrication; lubrication, if used, must be continuous				
Pressure range		X (pilot supply)		1-11 (valve supply)		
	Terminal 1-11	3 to 7 bar		vacuum at 10 bar		
	Terminal 1			3 to 7 bar		
Voltage range		24VDC ±10%				
Power for each pilot	W	0.9				
Solenoid Pilot Insulation class		F155				
Degree of protection		IP 65 (with conveyed exhaust, and unused INPUTS sealed with caps/plugs)				
Solenoid rating		100% ED				
Flow rate at 6.3 bar ΔP 1 bar	Nl/min	11.5 mm Ø 4	11.5 mm Ø 6	14 mm Ø 8	23 mm Ø 8	23 mm Ø 10
	version 5/2 and 3/2	200	500	650	1000	1200
	version 5/3	200	300	300	500	500
TRA/TRR 2x3/2 monostable at 6 bar	ms	8 / 45		8 / 60		
TRA/TRR 5/2 monostable at 6 bar	ms	8 / 33		9 / 60		
TRA/TRR 5/2 bistable at 6 bar	ms	20 / 20		8 / 8		
TRA/TRR 5/3 cc monostable at 6 bar	ms	20 / 20		15 / 15		
Note on use		Insert the pipes in the fittings, before passing air through the valves, otherwise the basket may be pulled out of its seat by the flow of air. *with right-end-plate 1-11 See chapter Z1				
Compatibility with oils						

## COMPONENTS

- Exhaust - Solenoid pilot 82/84
- Threaded connection of exhausts 3/5
- Valve supply - port 1-11-X
- Blind end-plate or right-end-plate 1-11
- Screw for valve wall-mounting
- Utility port for pipe Ø 4, 6, 8, 10 mm
- Manual control
- LED (LED on, solenoid valve energised)
- Pneumatic symbol
- Identification of the monostable or bistable manual control
- Valve ordering code
- Valve identification code
- Blank space for valve number
- Black cable for 24V (if present)
- AS-INTERFACE yellow cable
- AS-INTERFACE led

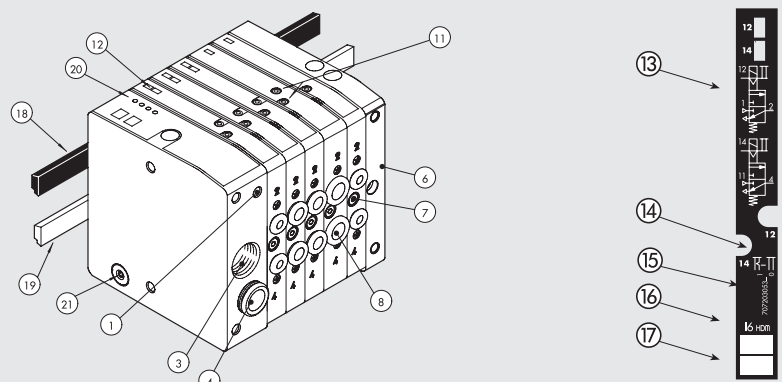

## THE MULTIMACH WORLD: FLEXIBILITY

The numbers permit rapid identification of the function and assembly position of the single elements represented as follows.

Refer to page B2.136 for valves, intermediates elements and common accessories.

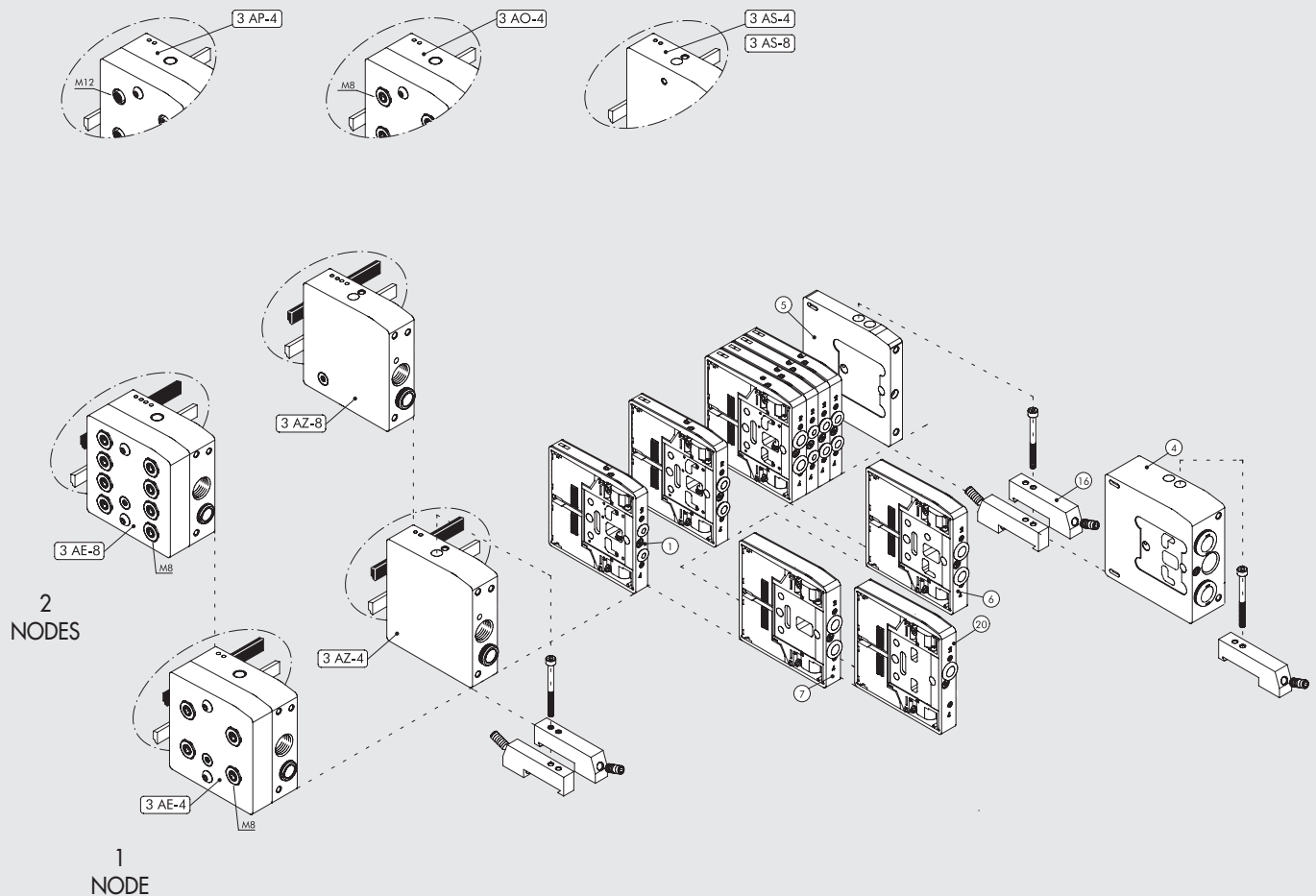

## FIXING THE BASE

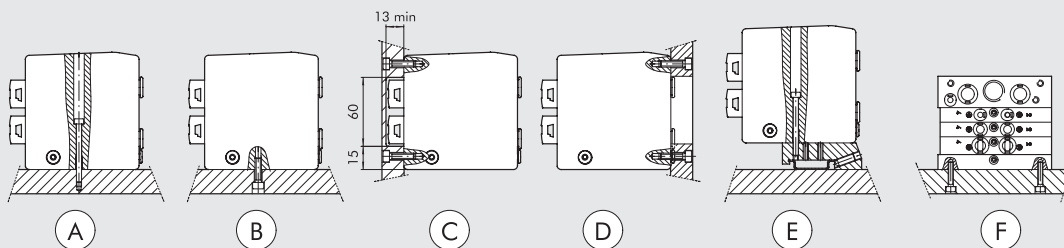

- Ⓐ Fixing from above using the 1 or 1-11 input terminal and the blind terminal.
- Ⓑ Ⓒ Fixing from above using the 1 or 1-11 input terminal and the blind terminal, using the M5 threads on the bottom and the rear of the terminals.
- Ⓓ Fixing from above using the 1 or 1-11 input terminal and the blind terminal, using the M5 threads on the front of the terminals.  
An opening for the pipes is made in the plate.
- Ⓔ Fixing on the DIN bar with end-plate 1 or 1-11 and blind and plate, using the push-in bracket code 0227301600.
- Ⓕ Lateral fixing using the blind terminal, and its M4 threads on the side lateral.

**Note: The sole fixing admitted is the one showed.**

**SYNOPTIC, SIZES AND VERSIONS**

H D M VALVE	3 INPUT END-PLATE	A S - 4 ELECTRICAL BASE	M MANUAL TYPE	16 - W 8 - 5 TYPE OF VALVE	1 6 FURTHER DETAILS
Heavy duty Multimach IP65	3 End-plate 1	Version with standard address <b>AS-4</b> 1 node, 4 out, yellow cable <b>AS-8</b> 2 nodes, 8 out, yellow cable <b>AO-4</b> 1 node, 4 out e 4 in M8, yellow cable <b>AP-4</b> 1 node, 4 out e 4 in M12, yellow cable <b>AZ-4</b> 1 node, 4 out, yellow cable and black cable <b>AZ-8</b> 2 nodes, 8 out, yellow cable and black cable <b>AE-4</b> 1 node, 4 out e 4 in M8, yellow cable and black cable <b>AE-8</b> 2 nodes, 8 out e 8 in M8, yellow cable and black cable	<b>M</b> Monostable manual control  <b>B</b> Bistable manual control	<b>I</b> n° 2 3/2 NC <b>W</b> n° 2 3/2 NO <b>L</b> 3/2 NO + 3/2 NC <b>V</b> 5/2 monostable <b>K</b> 5/2 bistable <b>O</b> 5/3 monostable <b>*F</b> 5/2 monostable <b>4</b> right-end-plate 1-11 pipe Ø12 <b>5</b> blind end-plate <b>6</b> Passing-intermede <b>7</b> Blind intermediate <b>20</b> Exhaust section <hr/> <b>4</b> Cartridge 4 <b>6</b> Cartridge 6 <b>8</b> Cartridge 8 - 14 mm <b>8S</b> Cartridge 8 - 23 mm <b>10</b> Cartridge 10	<b>16</b> n° 2 brackets for DIN bar

\* Uses a single PIN (like the V) and occupies 2 signals

**WIRING DIAGRAM**

**NOTE:** The type f monostable valve uses one PIN only (like the V) but occupies 2 signals.

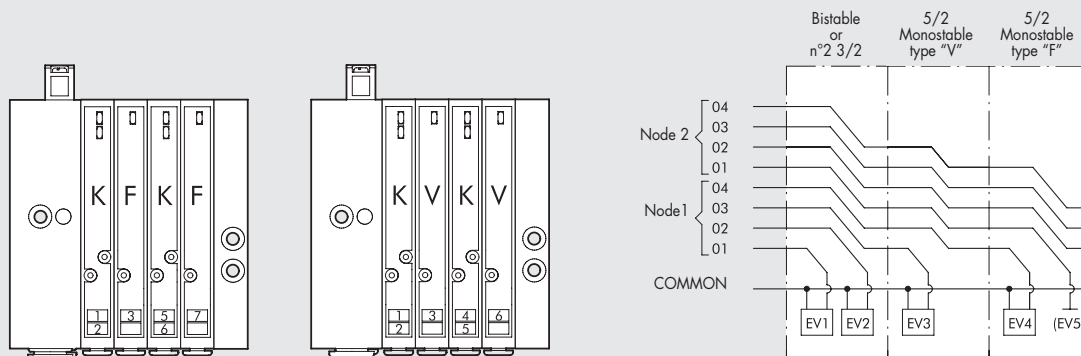

**3 END-PLATE 1 AS-4, AS-8**

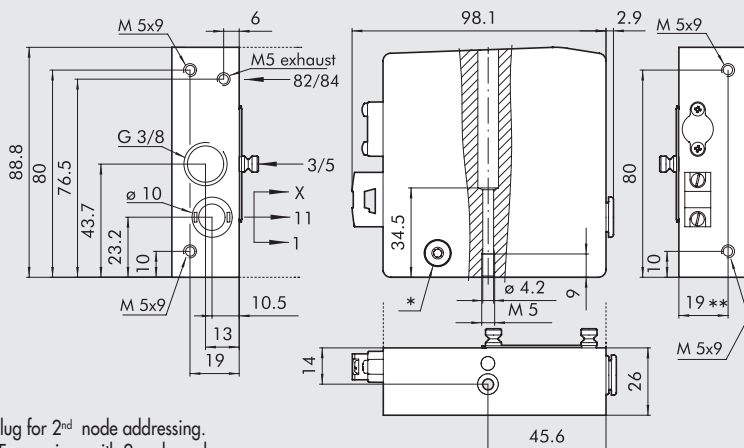

\* M7 plug for 2<sup>nd</sup> node addressing.  
N.B. For versions with 2 nodes only  
\*\* 21 for AS-8

Code	Description	Weight [g]
<b>0227301202</b>	End-plate HDM 1 AS-4 1 node, 4 Out, yellow cable	465
<b>0227301208</b>	End-plate HDM 1 AS-8 2 nodes, 8 Out, yellow cable	454

③ END-PLATE 1 AO-4, M8

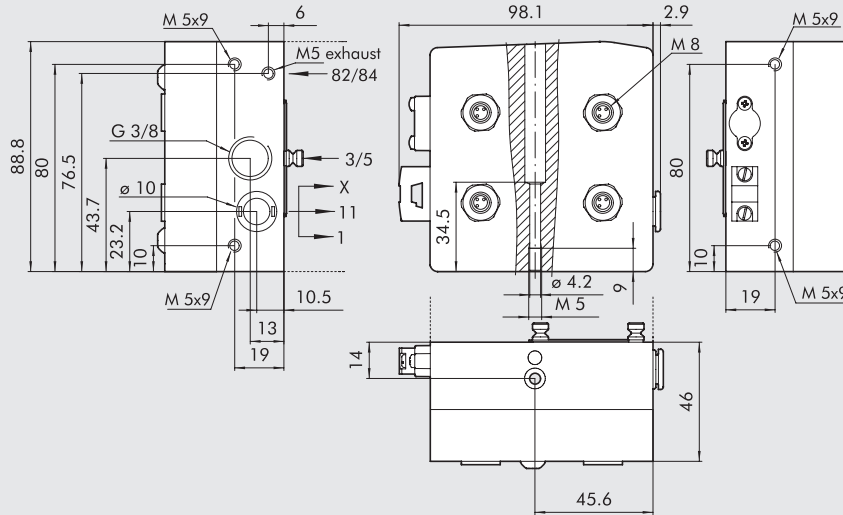

Code	Description	Weight [g]
0227301218	End-plate HDM 1 AO-4 1 node, 4 Out and 4 In M8, yellow cable	759

③ END-PLATE 1 AP-4, M12

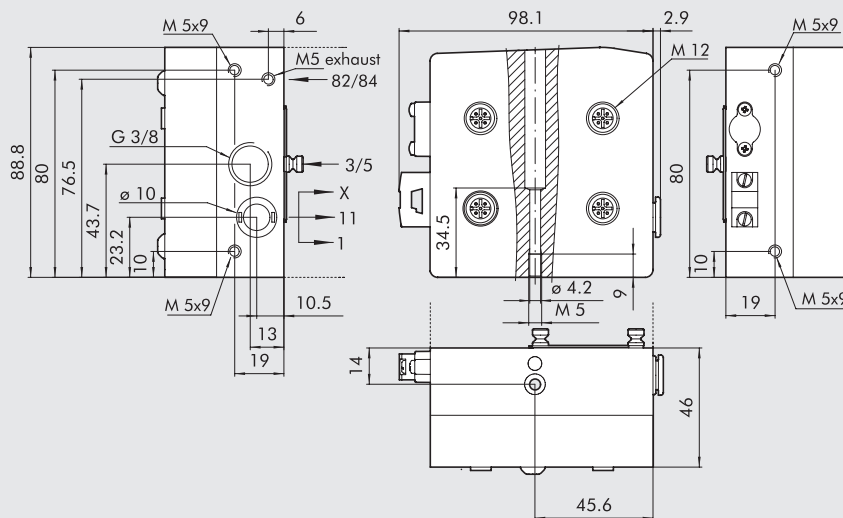

Code	Description	Weight [g]
0227301212	End-plate HDM 1 AP-4 1 node, 4 Out and 4 In M12, yellow cable	756

③ END-PLATE 1 AE-4, M8

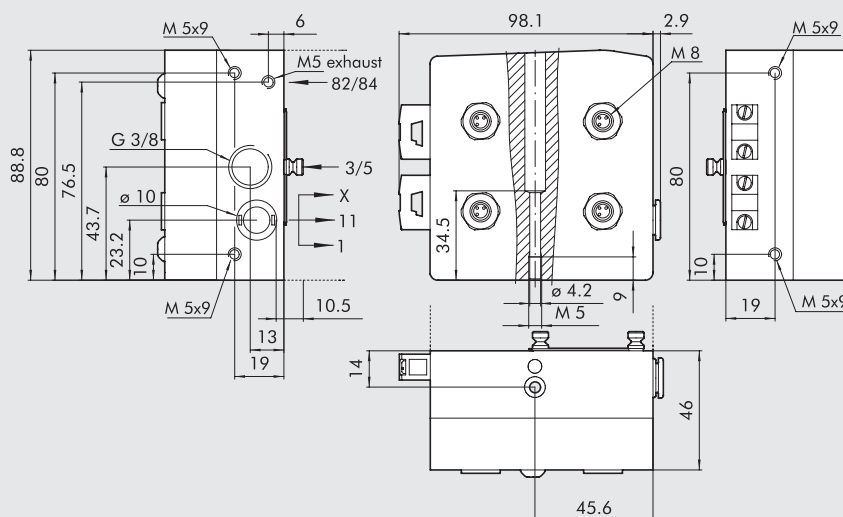

Code	Description	Weight [g]
0227301214	End-plate HDM 1 AE-4 1 node, 4 Out and 4 In M8, yellow cable and black cable	761

③ END-PLATE 1 AE-8, M8

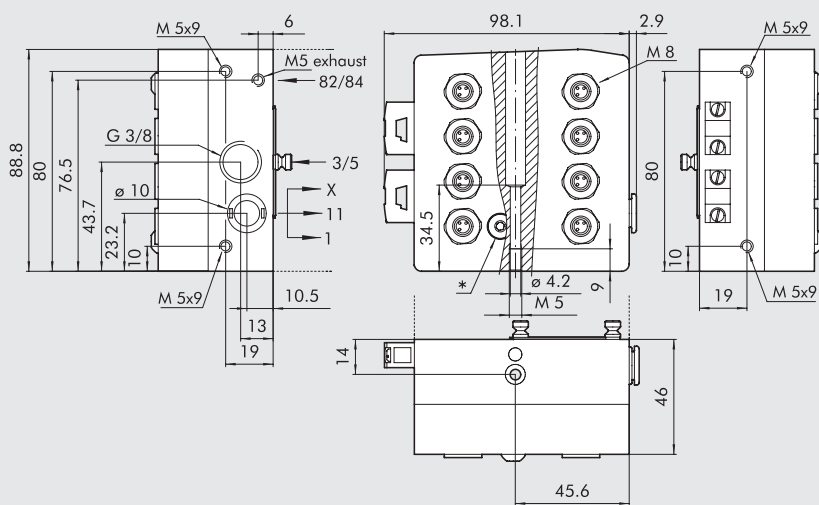

Code	Description	Weight [g]
0227301216	End-plate HDM 1 AE-8 2 nodes, 8 Out and 8 In M8, yellow cable and black cable	773

③ END-PLATE 1 AZ-4, AZ-8

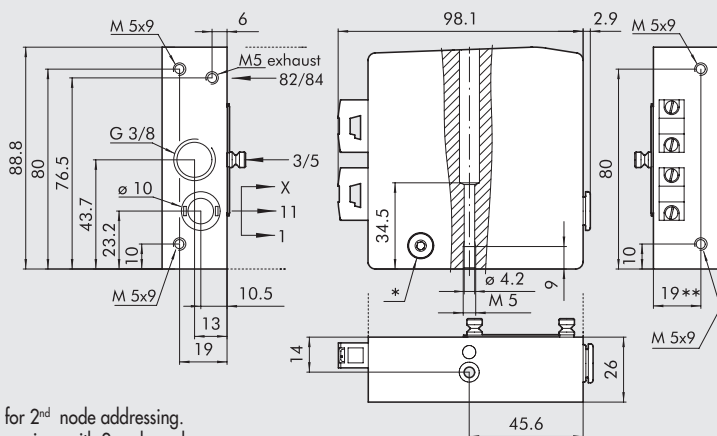

Code	Description	Weight [g]
0227301204	End-plate HDM 1 AZ-4 1 node, 4 Out, yellow cable and black cable	467
0227301210	End-plate HDM 1 AZ-8 2 nodes, 8 Out, yellow cable and black cable	456

\* M7 plug for 2<sup>nd</sup> node addressing.  
N.B. For versions with 2 nodes only  
\*\* 21 for AZ-8

ACCESSORIES

AS-interface ADDRESS CONNECTOR KIT

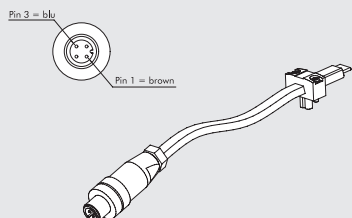

Code	Description
0226950150	AS-interface address connector cable L = 1 m

M8 - M12 PLUG



Code	Description
0240009039	PLUG M8
0240009040	PLUG M12

SPARES

AS-interface CONNECTOR KIT

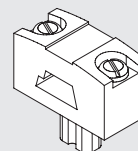

Code	Description
0226950151	AS-interface connector kit

# HDM + PROFIBUS-DP



The HDM+PROFIBUS system has been designed in such a way that the pneumatic input terminal contains all the electronics, signals and connectors. It is a very compact and sturdy system where everything is housed in a thick casing aluminium to protect the delicate components against impact. The valves and accessories are HDM standard, which means that you only need to replace the input terminal to convert the valve island with multiple connector into an PROFIBUS island. All the advantages of the HDM system can be exploited: the possibility of mounting valves of different size, with fittings for pipes 4, 6, 8 or 10; the insertion of intermediate modules with separate power supply or outlets; aluminium valves with chemical nickel plating enclosed in a protective casing in reinforced technopolymer, with an index of protection IP65.

The arrangement of the functions continues the traditional optimisation of the HDM: the user interface of the valves and bus all on one side, so that the fitter and service engineer have everything within easy reach: all compressed air connections are on the other side, and the electrical connectors and selectors are at the end of the island.

**It is advisable to grounding the system to prevent electrical or electrostatic discharge from damaging the electronic circuit.**



VALVES

HDM + PROFIBUS-DP

TECHNICAL DATA						
Valve port connections		Ø 4,6,8,10 mm automatic fitting for ports 2 and 4 / power supply port for Ø10 or 12* automatic fitting / 3/8 thread for exhaust port, M5 thread for exhaust pilot port				
Connection on the end-plate 1-11 for the supply of pilots		Automatic fitting Ø 4 mm				
Maximum number of pilots		16				
Maximum number of valves		16 (same as the max. no. of pilots)				
Operating temperature range	°C	-10 to +60				
Fluid		Filtered air without lubrication; lubrication, if used, must be continuous				
Pressure range		X (pilot supply)		1-11 (valve supply)		
	Terminal 1-11	3 to 7 bar		vacuum at 10 bar		
	Terminal 1		3 to 7 bar			
Voltage range		24 VDC ±10% (slave protected against overload and reverse polarity)				
Power for each pilot	W	0.9				
Solenoid Pilot Insulation class		F155				
Degree of protection		IP65 (with conveyed exhaust, and that - in case of no use - the BUS OUT connector gets plugged)				
Solenoid rating		100% ED				
Flow rate at 6.3 bar ΔP 1 bar	Nl/min	11.5 mm Ø 4	11.5 mm Ø 6	14 mm Ø 8	23 mm Ø 8	23 mm Ø 10
	version 5/2 and 3/2	200	500	650	1000	1200
	version 5/3	200	300	300	500	500
TRA/TRR 2x3/2 monostable at 6 bar	ms	8 / 45			8 / 60	
TRA/TRR 5/2 monostable at 6 bar	ms	8 / 33			9 / 60	
TRA/TRR 5/2 bistable at 6 bar	ms	20 / 20			8 / 8	
TRA/TRR 5/3 cc monostable at 6 bar	ms	20 / 20			15 / 15	
Note on use		Insert the pipes in the fittings, before passing air through the valves, otherwise the gasket may be pulled out of its seat by the flow of air. *with right-end-plate 1-11 See <b>chapter Z1</b>				
Compatibility with oils						
<b>Profibus-DP module for HDM valves</b>						
Protection		Outputs protected against overloads and shortcircuits				
Max input power (all valves ON)		~500 mA				
Addressing		By rotary selectors				
Highest settable address number		99				
Default address		3				
Peripheral defect diagnosis		Local LED indicator and relay to Master				
Defects reported		Output shortcircuit or overload. Auxiliary power supply failure. Profibus communication active.				
Module status in the event of peripheral defect		The "peripheral defect" bit is active and accessible at the master station.				
Data bit value		0 = not enabled 1 = enabled				
Output status in the absence of communication		Disabled				

COMPONENTS

- ① Exhaust - Solenoid pilot 82/84
- ② Valve supply - port 1
- ③ Threaded connection of exhausts 3/5
- ④ Valve supply - port 11
- ⑤ Electrical control supply X
- ⑥ Blind end-plate or right-end-plate-1-11
- ⑦ Screw for valve wall-mounting
- ⑧ Utility port for pipe Ø 4, 6, 8 or 10 mm
- ⑪ Manual control
- ⑫ LED (LED on, solenoid valve energised)
- ⑬ Pneumatic symbol
- ⑭ Identification of the monostable or bistable manual control
- ⑮ Valve ordering code
- ⑯ Valve identification code
- ⑰ Blank space for valve number
- ⑱ Profibus terminal

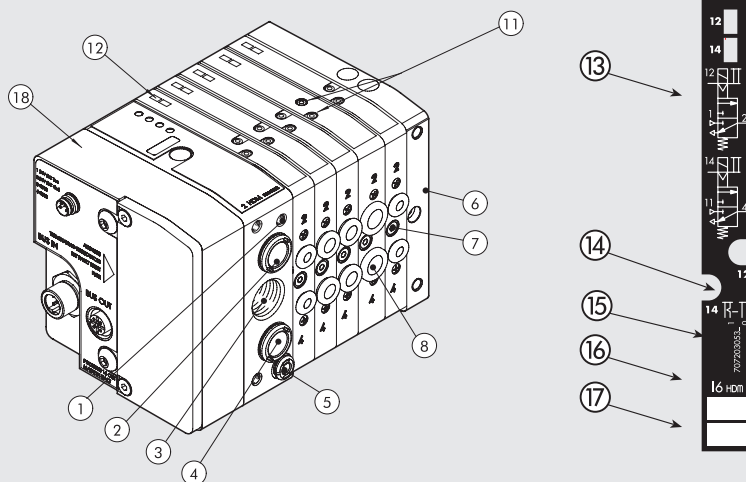

THE MULTIMACH WORLD: FLEXIBILITY

The numbers permit rapid identification of the function and assembly position of the single elements represented as follows.  
**Refer to page B2.136 for valves, intermediates elements and common accessories.**

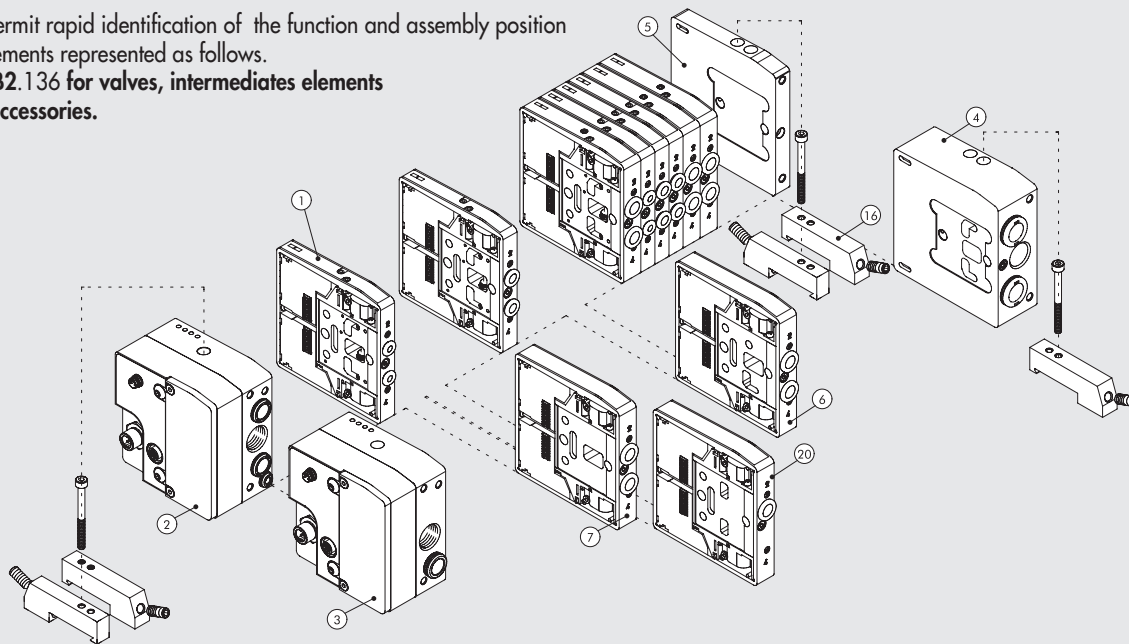

FIXING THE BASE

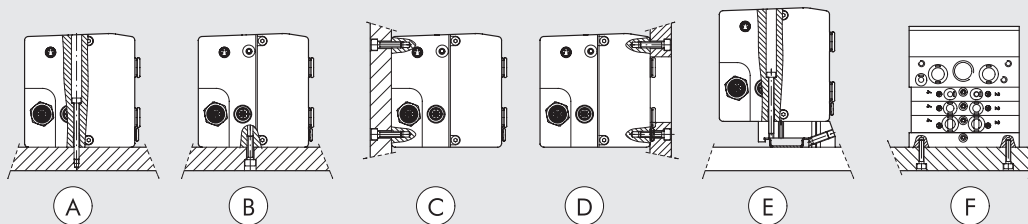

- Ⓐ Fixing from above using the 1 or 1-11 input terminal and the blind terminal.
  - Ⓑ Ⓒ Fixing from above using the 1 or 1-11 input terminal and the blind terminal, using the M5 threads on the bottom and the rear of the terminals.
  - Ⓓ Fixing from above using the 1 or 1-11 input terminal and the blind terminal, using the M5 threads on the front of the terminals.  
 An opening for the pipes is made in the plate.
  - Ⓔ Fixing on the DIN bar with end-plate 1 or 1-11 and blind and plate, using the push-in bracket code 0227301600.
  - Ⓕ Lateral fixing using the blind terminal, and its M4 threads on the side lateral.
- Note: The sole fixing admitted is the one showed.**

**SYNOPTIC, SIZES AND VERSIONS**

H D M VALVE	2 INPUT END-PLATE	P ELECTRICAL BASE	M MANUAL TYPE	16 - W 8 - W 6 - O 4 - L 8 - 5 TYPE OF VALVE	1 6 FURTHER DETAILS
Heavy duty Multimach IP65	2 End-plate 1-11 3 End-plate 1	P Profibus-DP	M Monostable manual control B Bistable manual control	I n° 2 3/2 NC W n° 2 3/2 NO L 3/2 NO + 3/2 NC V 5/2 monostable K 5/2 bistable O 5/3 monostable *F 5/2 monostable 4 right-end-plate 1-11 pipe Ø12 5 blind end-plate 6 Passing-intermediate 7 Blind intermediate 20 Exhaust section 4 Cartridge 4 6 Cartridge 6 8 Cartridge 8 - 14 mm 8S Cartridge 8 - 23 mm 10 Cartridge 10	16 n° 2 brackets for DIN bar

\* Uses a single PIN (like the V) and occupies 2 signals.

**WIRING DIAGRAM**

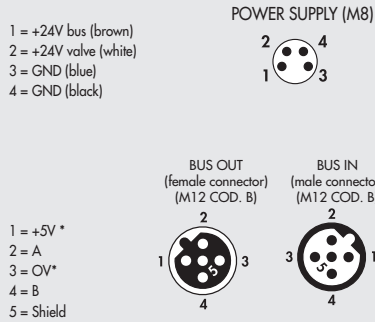

\* DO NOT CONNECT PIN 1 and PIN 3: to be used only for feeding of the external terminating resistors.  
- For correct communication, use Profibus cables at least 1 metre long.  
- The shield should be evenly distributed around the thread. Should this not be possible, the shield can be connected to prin 5. Both of these methods can also be used in combination.

- ① Addressing
- ② Terminal resistances
- ③ Reset button faulty
- ④ Resettable fuse
- ⑤ Indicator Led
- ⑥ Grounding

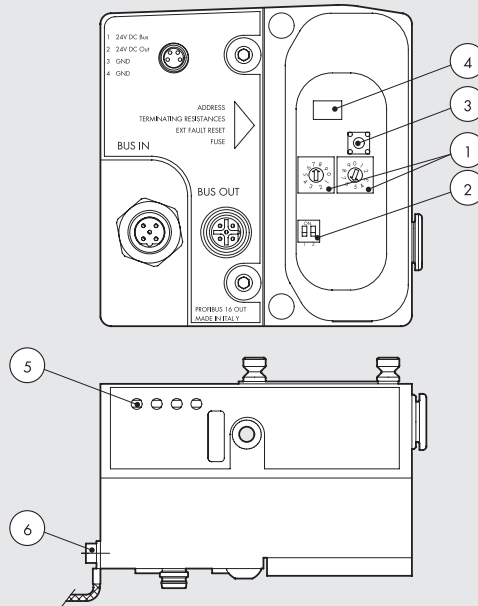

NOTE: The type F monostable valve uses one PIN only (like the V) but occupies 2 signals.

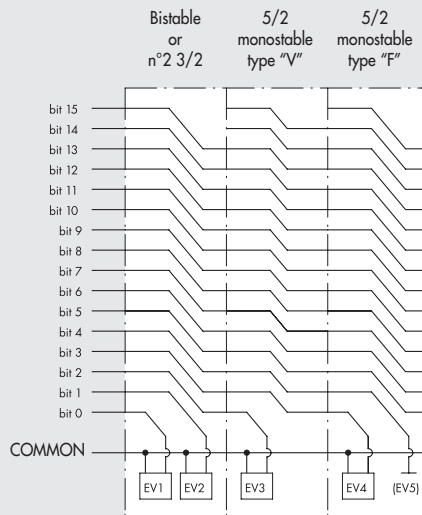

② END-PLATE 1-11 PROFIBUS-DP

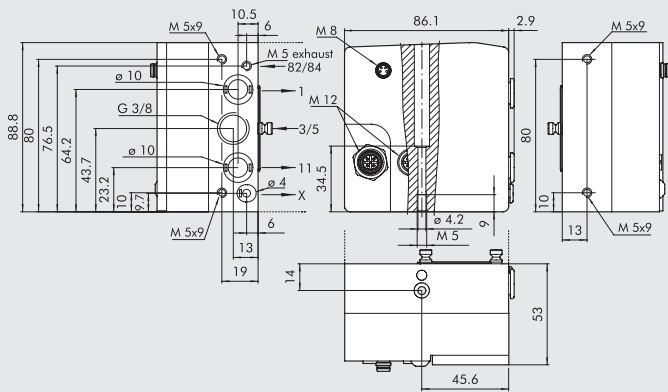

Code	Description	Weight [g]
0227301231	End-plate HDM 1-11 PROFIBUS	730

③ END-PLATE 1 PROFIBUS-DP

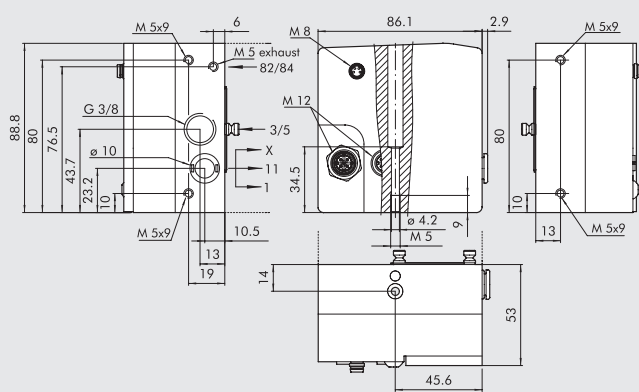

Code	Description	Weight [g]
0227301230	End-plate HDM 1 PROFIBUS	730

ACCESSORIES

M12 MALE CONNECTOR OUT-BUS

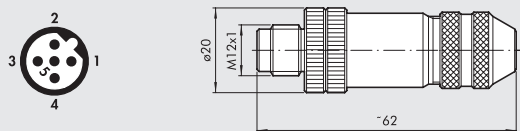

Code	Description
0240009035	M12 male connector B coding

M12 FEMALE CONNECTOR IN-BUS

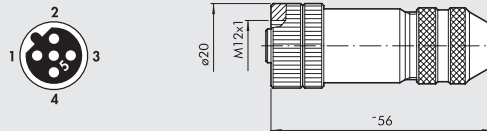

Code	Description
0240009036	M12 female connector B coding

M8 CONNECTOR FOR POWER SUPPLY

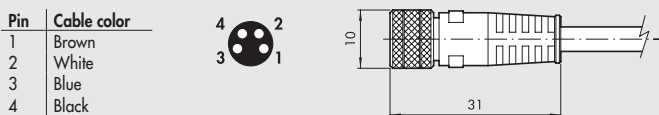

Pin	Cable color
1	Brown
2	White
3	Blue
4	Black

Code	Description
0240009060	M8 4-pin female connector for power supply, cable L = 3 m
0240009037	M8 4-pin female connector for power supply, cable L = 5 m
0240009058	M8 4-pin female connector for power supply, cable L = 10 m
0240009059	M8 4-pin female connector for power supply, cable L = 15 m
0240009P60 *	M8 4-pin female connector for power supply, H-FLEX CL6, cable L = 3 m
0240009P37 *	M8 4-pin female connector for power supply, H-FLEX CL6, cable L = 5 m
0240009P58 *	M8 4-pin female connector for power supply, H-FLEX CL6, cable L = 10 m
0240009P59 *	M8 4-pin female connector for power supply, H-FLEX CL6, cable L = 15 m

\* Very flexible cables, class 6 according to IEC 60228

M8 - M12 PLUG



Code	Description
0240009039	Plug M8
0240009040	Plug M12

# HDM + EtherNet/IP



The HDM+EtherNet/IP system has been designed in such a way that the pneumatic input terminal contains all the electronics, signals and connectors. It is a very compact and sturdy system where everything is housed in a thick casing aluminium to protect the delicate components against impact.

The valves and accessories are HDM standard, which means that you only need to replace the input terminal to convert the valve island with multiple connector into an EtherNet/IP island. All the advantages of the HDM system can be exploited: the possibility of mounting valves of different size, with fittings for pipes 4, 6, 8 or 10; the insertion of intermediate modules with separate power supply or outlets; aluminium valves with chemical nickel plating enclosed in a protective casing in reinforced technopolymer, with an index of protection IP65.

The arrangement of the functions continues the traditional optimisation of the HDM: the user interface of the valves and bus all on one side, so that the fitter and service engineer have everything within easy reach: all compressed air connections are on the other side, and the electrical connectors and selectors are at the end of the island.

**It is advisable to grounding the system to prevent electrical or electrostatic discharge from damaging the electronic circuit.**



TECHNICAL DATA						
Valve port connections		Ø 4,6,8,10 mm automatic fitting for ports 2 and 4 / power supply port for Ø10 or 12* automatic fitting / 3/8 thread for exhaust port, M5 thread for exhaust pilot port				
Connection on the end-plate 1-11 for the supply of pilots		Automatic fitting Ø 4 mm				
Maximum number of pilots		16				
Maximum number of valves		16 (same as the max. no. of pilots)				
Operating temperature range	°C	-10 to +60				
Fluid		Filtered air without lubrication; lubrication, if used, must be continuous				
Pressure range	Terminal 1-11	X (pilot supply)		1-11 (valve supply)		
	Terminal 1	3 to 7 bar		vacuum at 10 bar		
Voltage range		3 to 7 bar				
		24 VDC ±10%				
		(slave protected against overload and reverse polarity)				
Power for each pilot	W	0.9				
Solenoid Pilot Insulation class		F155				
Degree of protection		IP65 (with conveyed exhaust, and that - in case of no use - the BUS OUT connector gets plugged)				
Solenoid rating		100% ED				
Flow rate at 6.3 bar ΔP 1 bar	Nl/min	11.5 mm Ø 4	11.5 mm Ø 6	14 mm Ø 8	23 mm Ø 8	23 mm Ø 10
	version 5/2 and 3/2	200	500	650	1000	1200
	version 5/3	200	300	300	500	500
TRA/TRR 2x3/2 monostable at 6 bar	ms	8 / 45			8 / 60	
TRA/TRR 5/2 monostable at 6 bar	ms	8 / 33			9 / 60	
TRA/TRR 5/2 bistable at 6 bar	ms	20 / 20			8 / 8	
TRA/TRR 5/3 cc monostable at 6 bar	ms	20 / 20			15 / 15	
Note on use		Insert the pipes in the fittings, before passing air through the valves, otherwise the gasket may be pulled out of its seat by the flow of air. *with right-end-plate 1-11 See <b>chapter Z1</b>				
Compatibility with oils						
<b>EtherNet/IP module for HDM valves</b>						
Field buses		EtherNet/IP - 10/100 Mbit/s - Half-duplex - Full-duplex - Supports Auto-Negotiation				
Factory settings		Module name: Cmseries - Address IP 192.168.192.30				
Addressing		Software DHCP/BOOTP				
Voltage range		24VDC ± 10%				
Maximum number of pilots (Out)		16				
Maximum number of valves		16 (depending on the maximum number of solenoids)				
Icc bus supply current		Nominal Icc 120 mA - Instantaneous Icc (< 2 ms) 450 mA				
Maximum absorption of a valve distribution block with 16 mono-stable valves		Nominal Icc with 120mA OFF valves - Nominal Icc with 580 mA ON valves				
Protections		Module protected against overload and polarity reversal. Outputs protected against overloads and short-circuits				
Connections		Field bus: 2 M12 Female, D-coded, internal switch Supply: M8 4 pin - input: M8 3 pin				
Data bit value		0 = not enabled - 1 = enabled				
Output status in the absence of communication		Disabled				

COMPONENTS

- ① Exhaust - Solenoid pilot 82/84
- ② Valve supply - port 1
- ③ Threaded connection of exhausts 3/5
- ④ Valve supply - port 11
- ⑤ Electrical control supply X
- ⑥ Blind end-plate or right-end-plate-1-11
- ⑦ Screw for valve wall-mounting
- ⑧ Utility port for pipe Ø 4, 6, 8 or 10 mm
- ⑪ Manual control
- ⑫ LED (LED on, solenoid valve energised)
- ⑬ Pneumatic symbol
- ⑭ Identification of the monostable or bistable manual control
- ⑮ Valve ordering code
- ⑯ Valve identification code
- ⑰ Blank space for valve number
- ⑱ Profibus EtherNet/IP

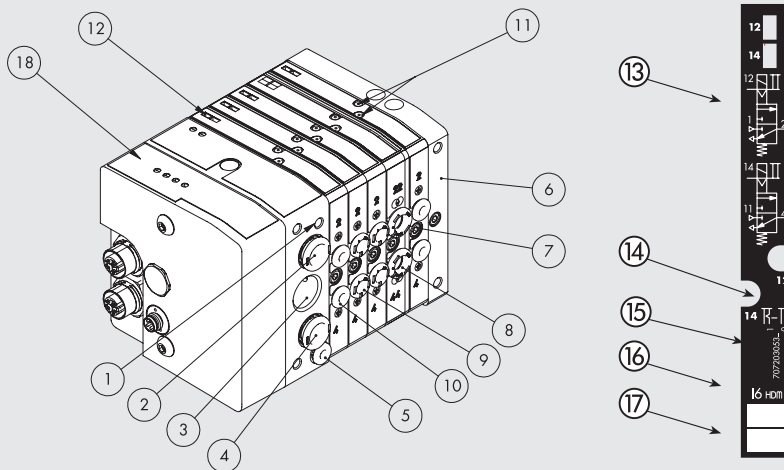

THE MULTIMACH WORLD: FLEXIBILITY

The numbers permit rapid identification of the function and assembly position of the single elements represented as follows.  
**Refer to page B2.136 for valves, intermediates elements and common accessories.**

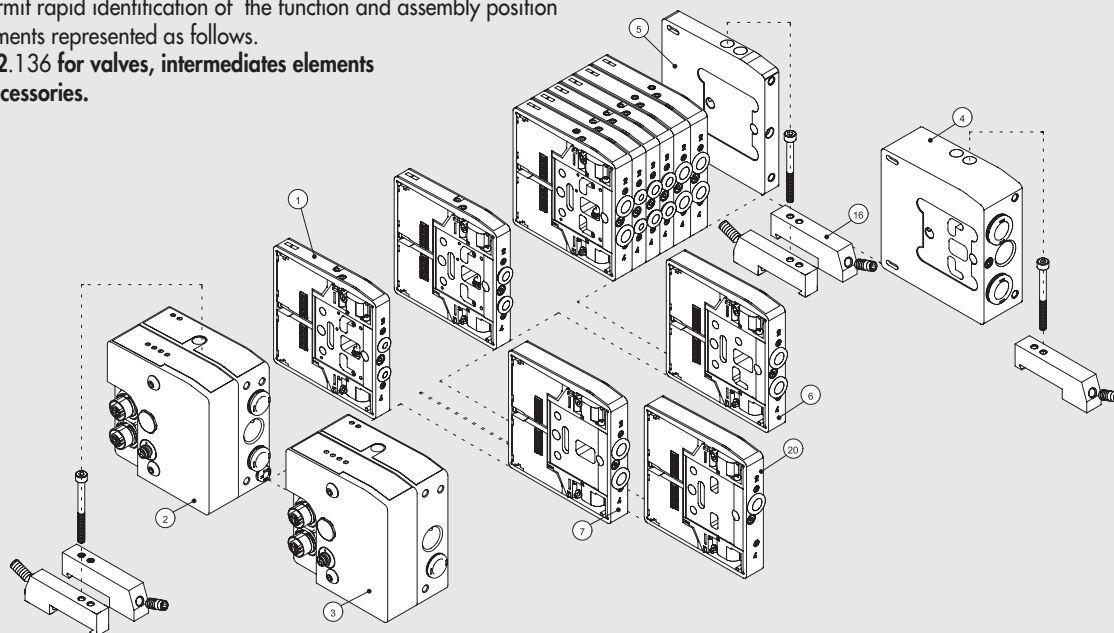

FIXING THE BASE

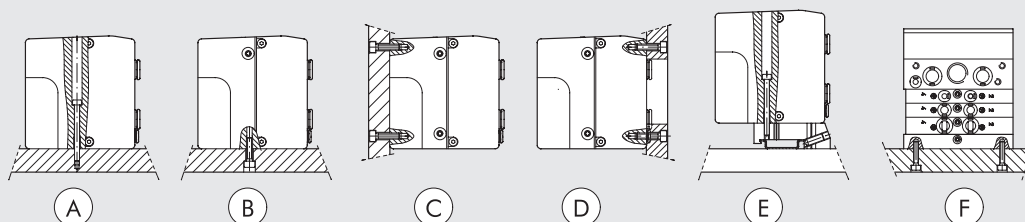

- Ⓐ Fixing from above using the 1 or 1-11 input terminal and the blind terminal.
  - Ⓑ Ⓒ Fixing from above using the 1 or 1-11 input terminal and the blind terminal, using the M5 threads on the bottom and the rear of the terminals.
  - Ⓓ Fixing from above using the 1 or 1-11 input terminal and the blind terminal, using the M5 threads on the front of the terminals.  
 An opening for the pipes is made in the plate.
  - Ⓔ Fixing on the DIN bar with end-plate 1 or 1-11 and blind and plate, using the push-in bracket code 0227301600.
  - Ⓕ Lateral fixing using the blind terminal, and its M4 threads on the side lateral.
- Note: The sole fixing admitted is the one showed.**

**SYNOPTIC, SIZES AND VERSIONS**

H D M VALVE	2 INPUT END-PLATE	EN ELECTRICAL BASE	M MANUAL TYPE	16 - W 8 - W 6 - O 4 - L 8 - 5 TYPE OF VALVE	1 6 FURTHER DETAILS
Heavy duty Multimach IP65	2 End-plate 1-11 3 End-plate 1	EN EtherNet/IP	M Monostable manual control B Bistable manual control	I n° 2 3/2 NC W n° 2 3/2 NO L 3/2 NO + 3/2 NC V 5/2 monostable K 5/2 bistable O 5/3 monostable *F 5/2 monostable 4 right-end-plate 1-11 pipe Ø12 5 blind end-plate 6 Passing-intermediate 7 Blind intermediate 20 Exhaust section 4 Cartridge 4 6 Cartridge 6 8 Cartridge 8 - 14 mm 8S Cartridge 8 - 23 mm 10 Cartridge 10	16 n° 2 brackets for DIN bar

\* Uses a single PIN (like the V) and occupies 2 signals.

**WIRING DIAGRAM**

- Ⓐ Connection to the EtherNet/IP network
- Ⓑ Connection for node supply and auxiliary valve supply
- Ⓒ HDM diagnostics indicator light
- Ⓓ EtherNet/IP diagnostics indicator light

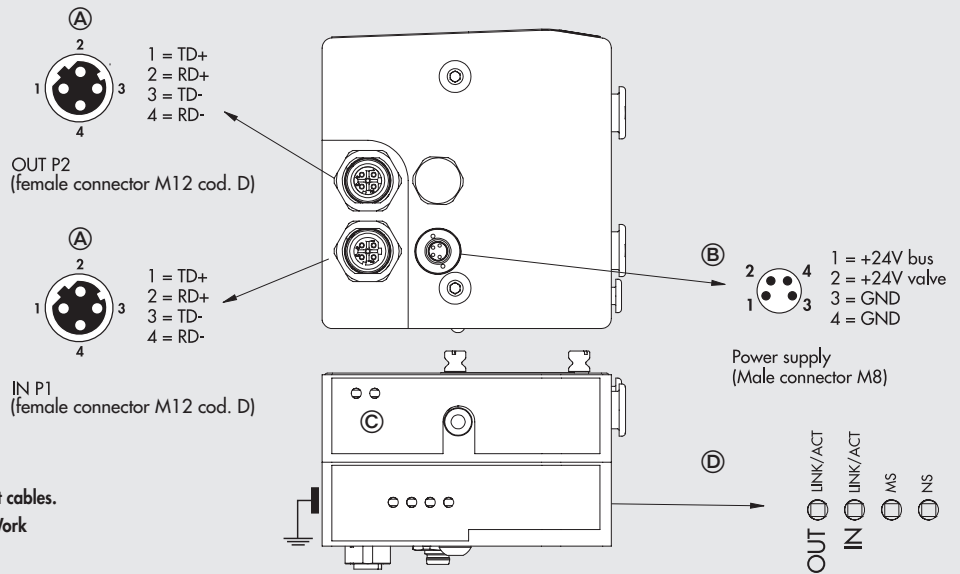

**WARNING**

For correct communication use only Industrial Ethernet cables. Cat. 5 / Class D 100 MHz, like the one in the Metal Work catalogue.

NOTE: The type F monostable valve uses one PIN only (like the V) but occupies 2 signals.

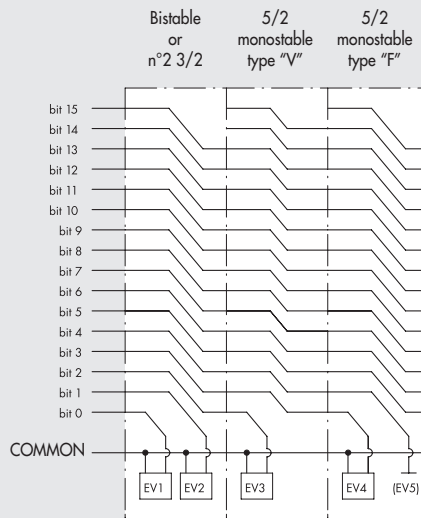



## ACCESSORIES

### M8 CONNECTOR FOR POWER SUPPLY

Pin	Cable color
1	Brown
2	White
3	Blue
4	Black

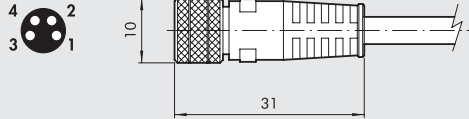

Code	Description
0240009060	M8 4-pin female connector for power supply, cable L = 3 m
0240009037	M8 4-pin female connector for power supply, cable L = 5 m
0240009058	M8 4-pin female connector for power supply, cable L = 10 m
0240009059	M8 4-pin female connector for power supply, cable L = 15 m
0240009P60 *	M8 4-pin female connector for power supply, H-FLEX CL6, cable L = 3 m
0240009P37 *	M8 4-pin female connector for power supply, H-FLEX CL6, cable L = 5 m
0240009P58 *	M8 4-pin female connector for power supply, H-FLEX CL6, cable L = 10 m
0240009P59 *	M8 4-pin female connector for power supply, H-FLEX CL6, cable L = 15 m

\* Very flexible cables, class 6 according to IEC 60228

### M12 PLUG



Code	Description
0240009040	Plug M12

### M12 BUS CONNECTOR, D-CODED

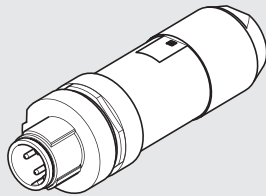

Code	Description
0240005051	M12 BUS connector, D-coded

Note: Can be used for BUS units in the EtherNet family (Profinet IO, EtherCAT, EtherNet/IP...)

### BUS CABLE



Code	Description
0240005220	BUS cable L = 20 m

Note: Can be used for BUS units in the EtherNet family (Profinet IO, EtherCAT, EtherNet/IP...)

### STRAIGHT CONNECTOR FOR M12-M12 BUS, D-CODED

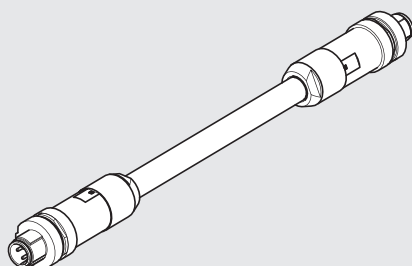

Code	Description
0240005103	Straight connector for M12-M12 BUS, D-coded, with 3 m cable
0240005105	Straight connector for M12-M12 BUS, D-coded, with 5 m cable
0240005110	Straight connector for M12-M12 BUS, D-coded, with 10 m cable

Note: Can be used for BUS units in the EtherNet family (Profinet IO, EtherCAT, EtherNet/IP...)

### STRAIGHT CONNECTOR FOR M12 BUS, D-CODED

Pin	Cable color
1	Yellow
2	White
3	Red
4	Blue

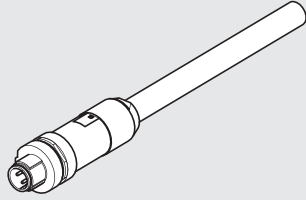
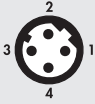

Code	Description
0240005093	Straight connector for M12 BUS, D-coded, with 3 m cable
0240005095	Straight connector for M12 BUS, D-coded, with 5 m cable
0240005100	Straight connector for M12 BUS, D-coded, with 10 m cable

Note: Can be used for BUS units in the EtherNet family (Profinet IO, EtherCAT, EtherNet/IP...)

### RJ45 CONNECTOR

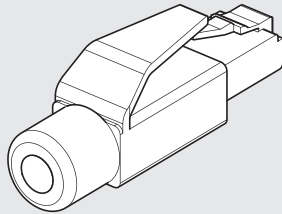

Code	Description
0240005050	RJ45 connector with 4 contacts according to IEC 60603-7

### NOTES

# HDM + CANopen



The HDM+CANopen system has been designed in such a way that the pneumatic input terminal contains all the electronics, signals and connectors. It is a very compact and sturdy system where everything is housed in a thick casing aluminium to protect the delicate components against impact. Two versions of end-plate are available: one can handle up to 16 controls (16 Out) and one up to 16 controls and 8 inputs (16 Out + 8 In). The input connectors are M12. Two inputs can be connected to each connector. The functions are arranged to ensure the same optimisation as the HDMs. The user interface is all on one side to facilitate the work of the fitter and service engineer. All pneumatic connections are on one side; the electrical connectors and selectors are on top of the island.



VALVES

HDM + CANopen

TECHNICAL DATA							
Valve port connections		Ø 4,6,8,10 mm automatic fitting for ports 2 and 4 / power supply port for Ø10 or 12* automatic fitting / 3/8 thread for exhaust port, M5 thread for exhaust pilot port					
Connection on the end-plate 1-11 for the supply of pilots		Automatic fitting Ø 4 mm					
Maximum number of pilots		16					
Maximum number of valves		16 (same as the max. no. of pilots)					
Operating temperature range	°C	-10 to +60					
Fluid		Filtered air without lubrication; lubrication, if used, must be continuous					
Pressure range	Terminal 1-11	X (pilot supply)		1-11 (valve supply)			
	Terminal 1	3 to 7 bar		vacuum at 10 bar			
Voltage range		3 to 7 bar					
		24VDC ±10%					
		(slave protected against overload and reverse polarity)					
Power for each pilot	W	0.9					
Solenoid Pilot Insulation class		F155					
Degree of protection		IP65 (with conveyed exhausts and with not used connectors plugged)					
Solenoid rating		100% ED					
Flow rate at 6.3 bar ΔP 1 bar	Nl/min	11.5 mm Ø 4	11.5 mm Ø 6	14 mm Ø 8	23 mm Ø 8	23 mm Ø 10	
		version 5/2 and 3/2	200	500	650	1000	1200
		version 5/3	200	300	300	500	500
TRA/TRR 2x3/2 monostable at 6 bar	ms	8 / 45			8 / 60		
TRA/TRR 5/2 monostable at 6 bar	ms	8 / 33			9 / 60		
TRA/TRR 5/2 bistable at 6 bar	ms	20 / 20			8 / 8		
TRA/TRR 5/3 cc monostable at 6 bar	ms	20 / 20			15 / 15		
Note on use		Insert the pipes in the fittings, before passing air through the valves, otherwise the gasket may be pulled out of its seat by the flow of air. * with right-end-plate 1-11 See chapter Z1					
Compatibility with oils							
<b>CANopen module for HDM valves</b>							
Protection		Outputs protected against overloads and shortcircuits					
Max input power (all valves ON)		~800 mA					
Addressing		By DIP SWITCH					
Highest settable address number		127					
Default address		1					
Peripheral defect diagnosis		Local LED indicator and relay to Master					
Defects reported		Output shortcircuit or overload.					
		Auxiliary power supply failure.					
Module status in the event of peripheral defect		CANopen communication active.					
		The "peripheral defect" bit is active and accessible at the master station.					
Data bit value		0 = not enabled					
		1 = enabled					
Output status in the absence of communication		Disabled					
<b>INPUT module for HDM valves</b>							
Sensor supply voltage		24 VDC ±10% (depending on the supply of the CANopen module)					
Max sensor power (distributed over eight connectors)	mA	40					
Type of input		PNP for sensor 2-3 wires according to EN 60947-5-2					
Protection		Protected inputs against overload and short-circuit					
Active INPUT signalling		One LED for each INPUT					

COMPONENTS

- ① Exhaust - Solenoid pilot 82/84
- ② Valve supply - port 1
- ③ Threaded connection of exhausts 3/5
- ④ Valve supply - port 11
- ⑤ Electrical control supply X
- ⑥ Blind end-plate or right-end-plate 1-11
- ⑦ Screw for valve wall-mounting
- ⑧ Utility port for pipe Ø 4, 6, 8 or 10 mm
- ⑪ Manual control
- ⑫ LED (LED on, solenoid valve energised)
- ⑬ Pneumatic symbol
- ⑭ Identification of the monostable or bistable manual control
- ⑮ Valve ordering code
- ⑯ Valve identification code
- ⑰ Blank space for valve number
- ⑱ CANopen terminal

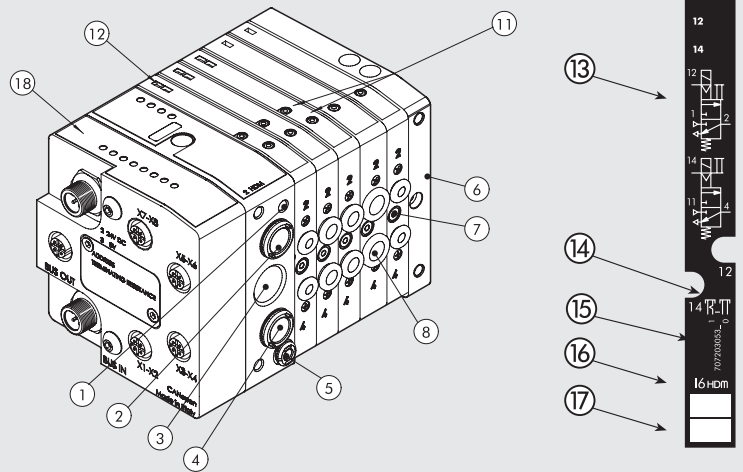

THE MULTIMACH WORLD: FLEXIBILITY

The numbers permit rapid identification of the function and assembly position of the single elements represented as follows.

Refer to page B2.136 for valves, intermediates elements and common accessories.

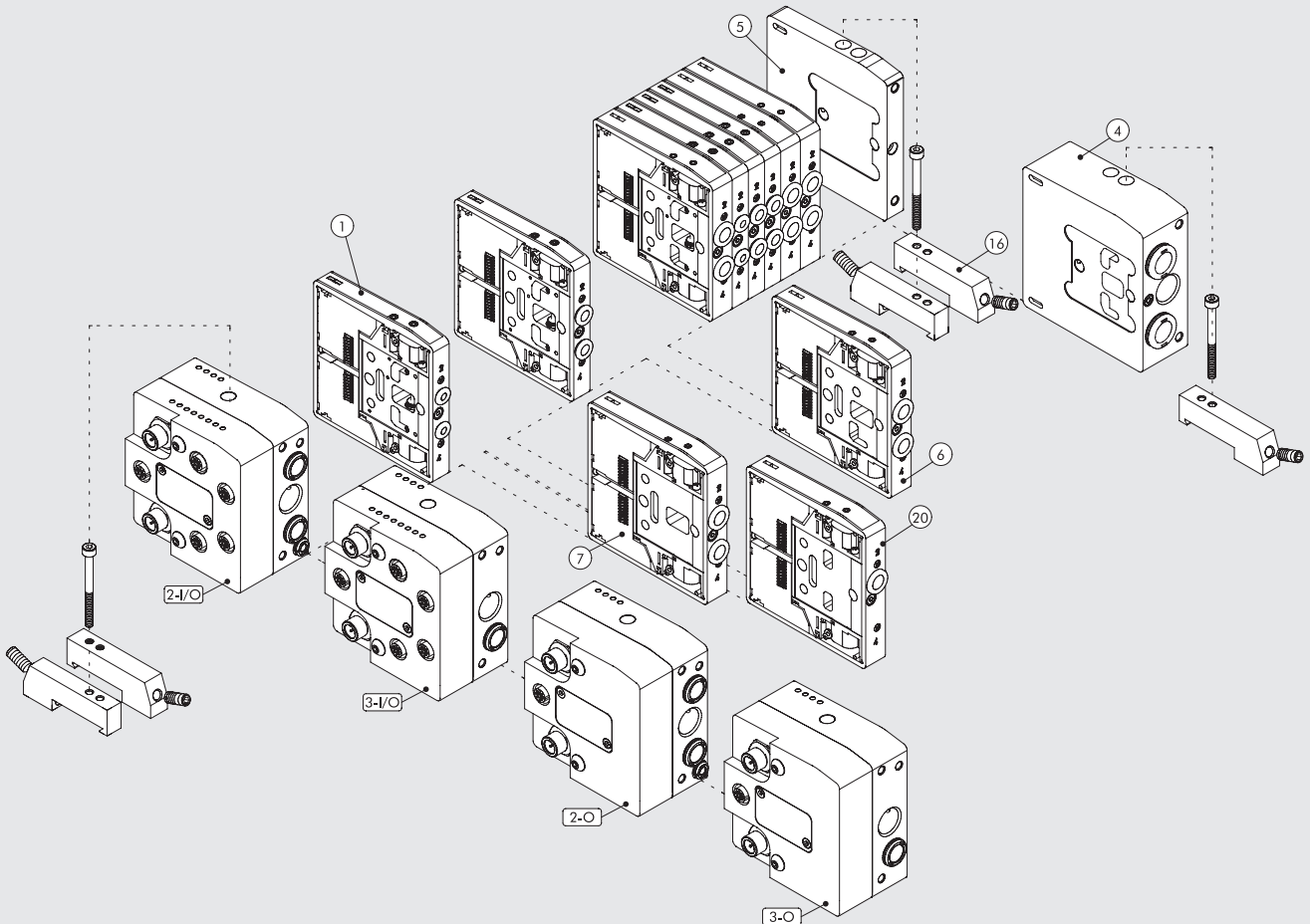

**FIXING THE BASE**

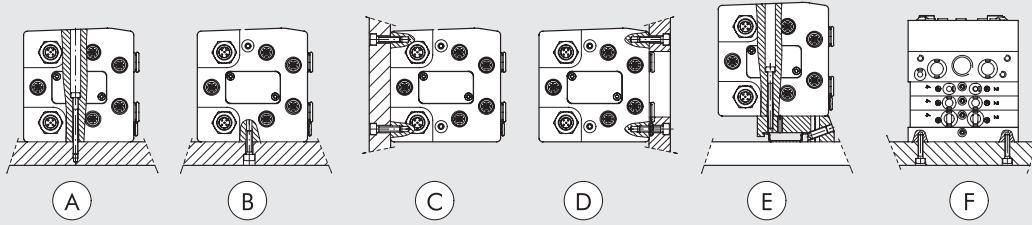

- (A) Fixing from above using the 1 or 1-11 input terminal and the blind terminal.
  - (B) (C) Fixing from above using the 1 or 1-11 input terminal and the blind terminal, using the M5 threads on the bottom and the rear of the terminals.
  - (D) Fixing from above using the 1 or 1-11 input terminal and the blind terminal, using the M5 threads on the front of the terminals.  
An opening for the pipes is made in the plate.
  - (E) Fixing on the DIN bar with end-plate 1 or 1-11 and blind and plate, using the push-in bracket code 0227301600.
  - (F) Lateral fixing using the blind terminal, and its the M4 threads on the side lateral.
- Note: The sole fixing admitted is the one showed.**

**SYNOPTIC, SIZES AND VERSIONS**

H D M VALVE	2 INPUT END-PLATE	CAN O ELECTRICAL BASE	M MANUAL TYPE	16 - W 8 - W 6 - O 4 - L 8 - 5 TYPE OF VALVE	1 6 FURTHER DETAILS
Heavy duty Multimach IP65	2 End-plate 1-11 3 End-plate 1	CAN O CANopen 16 OUTPUT CAN I/O CANopen 8 INPUT e 16 OUTPUT	M Monostable manual control B Bistable manual control	I n° 2 3/2 NC W n° 2 3/2 NO L 3/2 NO + 3/2 NC V 5/2 monostable K 5/2 bistable O 5/3 monostable *F 5/2 monostable 4 right-end-plate 1-11 pipe Ø12 5 blind end-plate 6 Passing-intermede 7 Blind intermediate 20 Exhaust section 4 Cartridge 4 6 Cartridge 6 8 Cartridge 8 - 14 mm 8S Cartridge 8 - 23 mm 10 Cartridge 10	16 n° 2 brackets for DIN bar

\* Uses a single PIN (like the V) and occupies 2 signals.

**WIRING DIAGRAM**

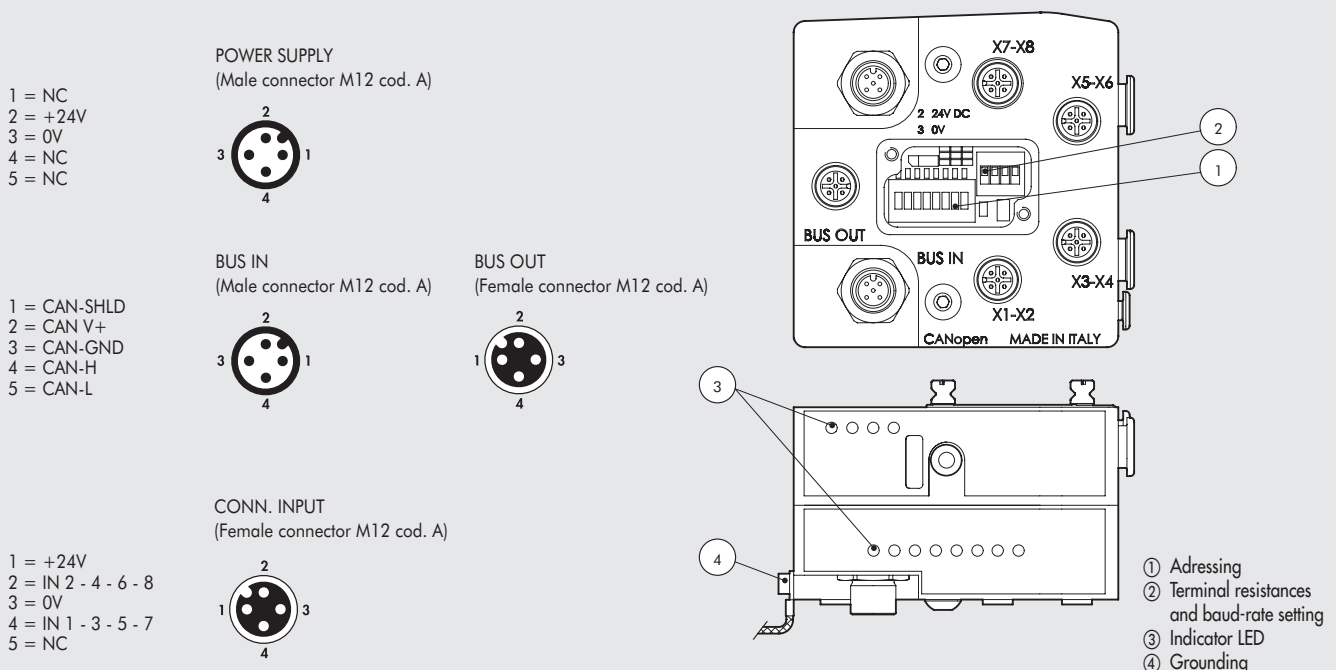

VALVES  
HDM + CANopen

**2 - O** END-PLATE 1-11 CANopen O

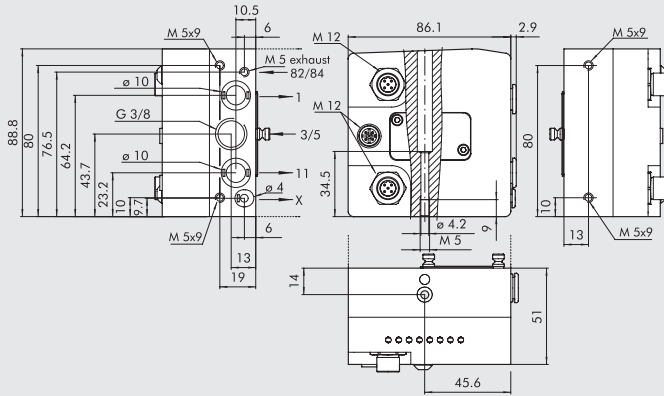

Code	Description	Weight [g]
0227301251	End-plate 1-11 HDM CANopen OUTPUT	745

Handles 16 OUTPUTS (solenoid pilots)

**3 - O** END-PLATE 1 CANopen O

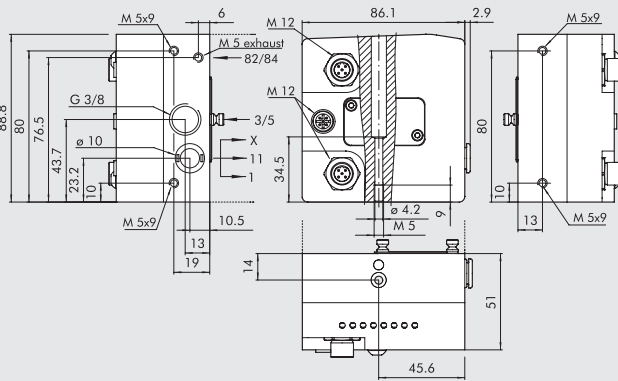

Code	Description	Weight [g]
0227301253	End-plate 1 HDM CANopen OUTPUT	746

Handles 16 OUTPUTS (solenoid pilots)

**2 - I/O** END-PLATE 1-11 CANopen I/O

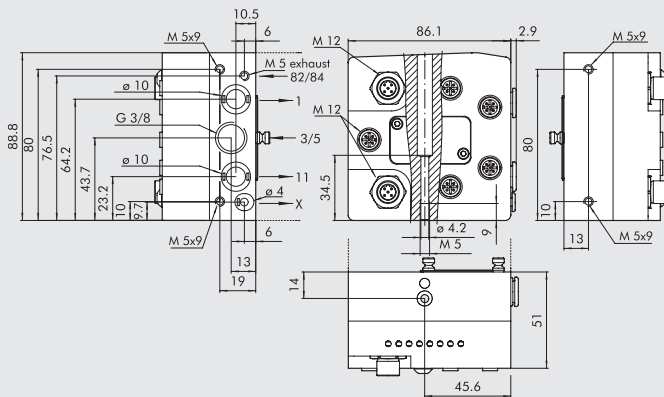

Code	Description	Weight [g]
0227301250	End-plate 1-11 HDM CANopen IN-OUT	734

Handles 16 OUTPUTS (solenoid pilots)

**3 - I/O** END-PLATE 1 CANopen I/O

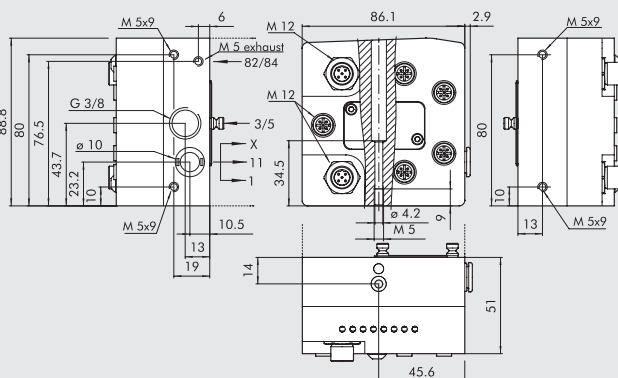

Code	Description	Weight [g]
0227301252	End-plate 1 HDM CANopen IN-OUT	735

Handles 16 OUTPUTS (solenoid pilots)

ACCESSORIES

STRAIGHT CONNECTOR FOR CANopen POWER SUPPLY

Code	Description
W0970513001	5-pin M12x1 straight connector

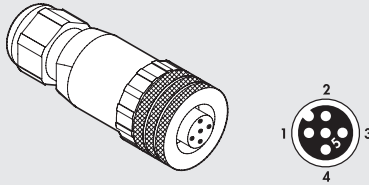

STRAIGHT CONNECTOR WITH CANopen POWER CABLE

Pin	Cable color
1	Brown
2	White
3	Blue
4	Black
5	Grey

Code	Description
W0970513002	5-pin M12x1 straight connector with wire L = 5 m

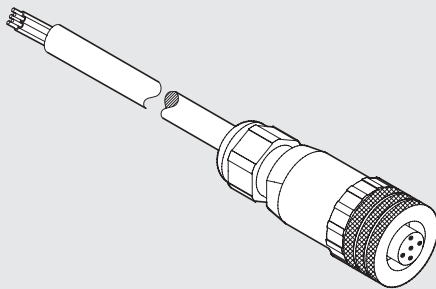

FEMALE CONNECTOR FOR CANopen BUS-IN

Code	Description
0240009055	M12 female connector, A coding

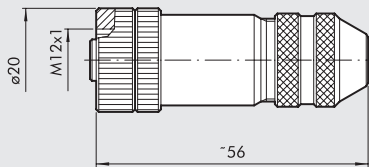
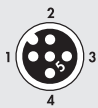

MALE CONNECTOR FOR CANopen BUS-OUT

Code	Description
0240009038	Male connector Bus A coding

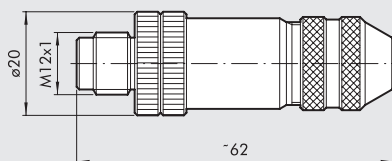
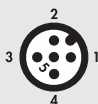

**STRAIGHT CONNECTOR WITHOUT CABLE FOR CANopen INPUT**

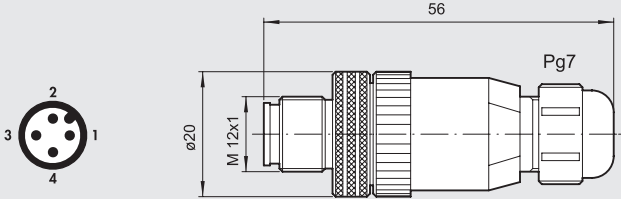

Code	Description
0240009021	Straight fitting without cable

**STRAIGHT CONNECTOR WITH CABLE FOR CANopen INPUT**

Pin	Cable colour
1	Brown
2	White
3	Blue
4	Black

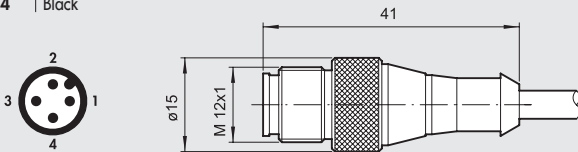

Code	Description
0240009002	Straight, with 1.5 m cable
0240009003	Straight, with 5 m cable

**Y-DISTRIBUTOR WITH CABLE AND M12 STRAIGHT CONNECTORS FOR CANopen INPUT**

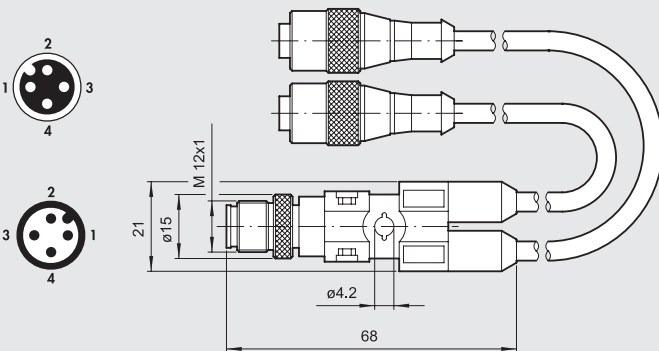

Code	Description
0240009031	Y-Distributor cable 0.6 m
0240009032	Y-Distributor cable 1.5 m

**M12 PLUG FOR BUS OUT E INPUT CANopen**



Code	Description
0240009040	Plug M12

# HDM + B&R



An advanced field bus system interfacing with the Multimach world. B&R has developed a new standard for automation, called FORMULA X. For further details about features, functions and qualities of this system, reference must be made to the B&R documentation, also available on the web site [www.br-automation.com](http://www.br-automation.com). An overview is given below.

The X-system is a system handling analogue and digital inputs and outputs for local or remote use, which B&R defines as decentralised backplane. Different types of modules are available. We present those designed for connection with Multimach and HDM valve islands. We only indicate the B&R's code root, since each type of module comes in different variants, that differ by number of signals handled, that can be 8, 16 or 24, and by type of signal, that can be input, output or input/output indifferently. Common to all the modules is the presence of 4 connections: a signal input, a signal output for the following modules, a power input (24V DC), a power output for the following modules.

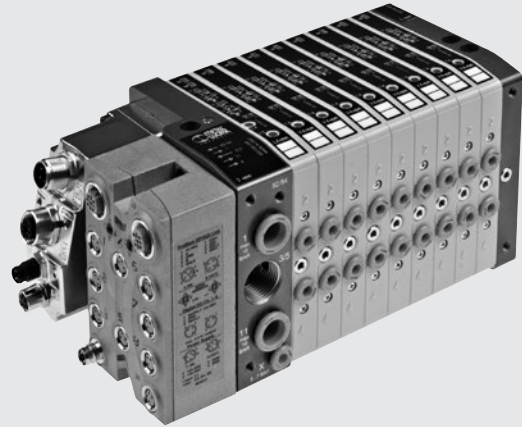

VALVES  
HDM + B&R

## B&R CONNECTORS AND MODULES

### IP20 7XV---50-11 SMART CONNECTOR

It is a plug connector with IP20 protection that contains the X system electronics. It can be connected with HDM islands, using the special input end-plate, type 1, code 0227301207 or the special input end-plate type 1-11, code 0227301206.

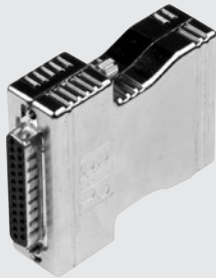

### IP67 7XV---50-51 SMART CONNECTOR

It is a plug connector with IP67 protection, that contains the X system electronics. It can be connected with HDM islands, using the special input end-plate type 1, code 0227301207, or the special input end-plate, type 1-11 code 0227301206.



### X67 I/O SYSTEM MODULES

These are modules with IP67 protection, connected to the X system, for handling inputs and outputs. It is interesting to note that their size is such that they can be fixed directly to the HDM input end-plate type 1-11, code 0227301206  
**(N.B. NOT to be fixed to the HDM end-plate type 1, code 0227301207).**

### X67 BUS CONTROLLER MODULES

These are modules with protection IP67, receiving a signal according to one of the DP Profibus, CAN open, Device Net, Ethernet Powerlink protocols (the module code differs obviously according to the protocol being controlled). The output signal is according to the X-system. These are gateways converting the signals of a field bus into an X-system. These modules control the inputs and/or outputs via the M8 connectors provided. They can be fixed directly to the HDM input end-plate type 1-11, code 0227301206  
**(N.B. NOT to be fixed to the HDM end-plate, type 1, code 0227301207).**

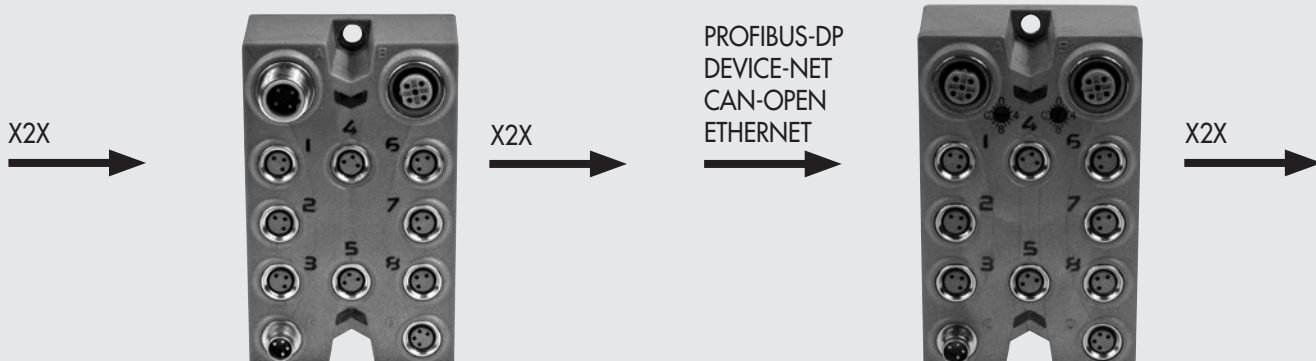

APPLICATIONS OF B&R MODULES TO HDM END-PLATES

Refer to page B2.136 for valves, intermediates elements and common accessories.

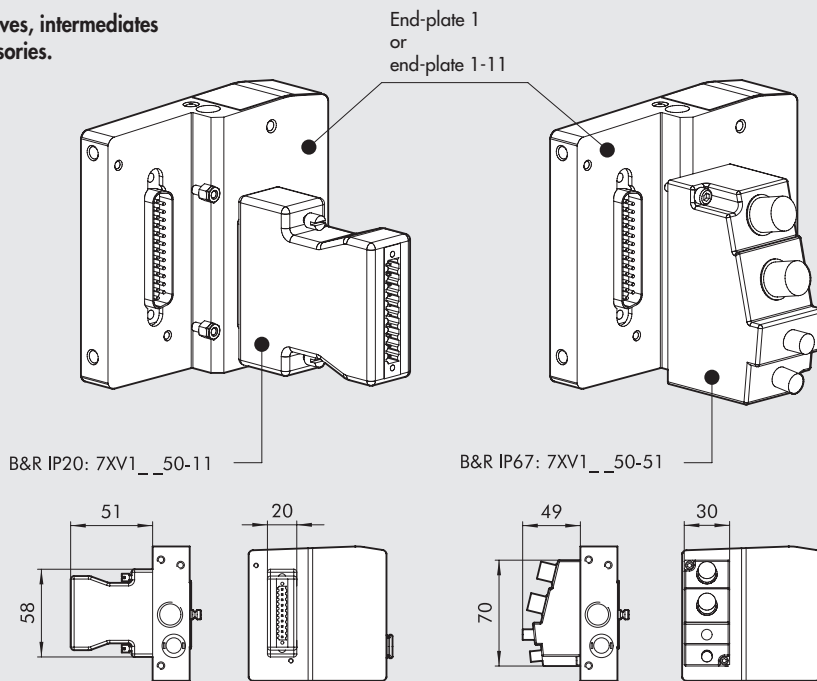

Refer to page B2.136 for valves, intermediates elements and common accessories.

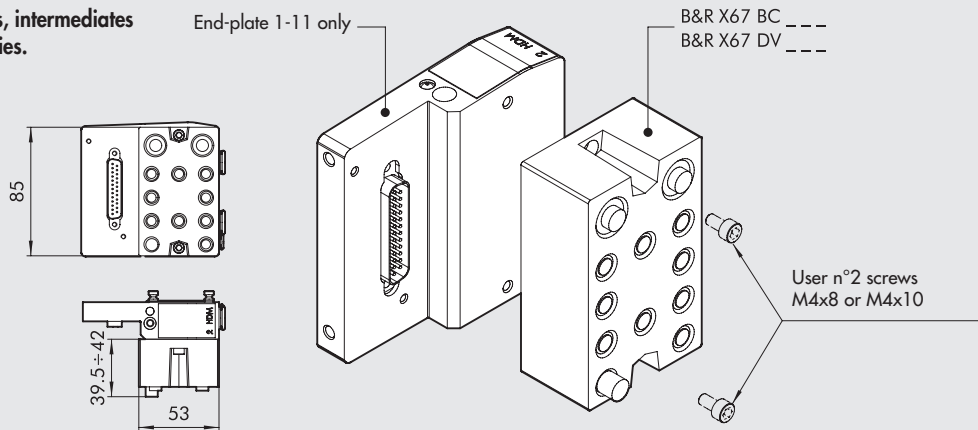

SYNOPTIC, SIZES AND VERSIONS

H D M VALVE	2 INPUT END-PLATE	B & R ELECTRICAL BASE	M MANUAL TYPE	16 - W 8 - W 6 - O 4 - L 8 - 5 TYPE OF VALVE	1 6 FURTHER DETAILS
Heavy duty Multimach IP65	2 End-plate 1-11 3 End-plate 1	B&R Fit for B&R	M Monostable manual control B Bistable manual control	I n° 2 3/2 NC W n° 2 3/2 NO L 3/2 NO + 3/2 NC V 5/2 monostable K 5/2 bistable O 5/3 monostable *F 5/2 monostable 4 Right-end-plate 1-11 pipe Ø12 5 Blind end-plate 6 Passing-intermede 7 Blind intermediate 20 Exhaust section 4 Cartridge 4 6 Cartridge 6 8 Cartridge 8 - 14 mm 85 Cartridge 8 - 23 mm 10 Cartridge 10	16 n° 2 brackets for DIN bar

\* Uses a single PIN (like the V) and occupies 2 signals.

**HDM 1-11 END-PLATE FOR B&R**

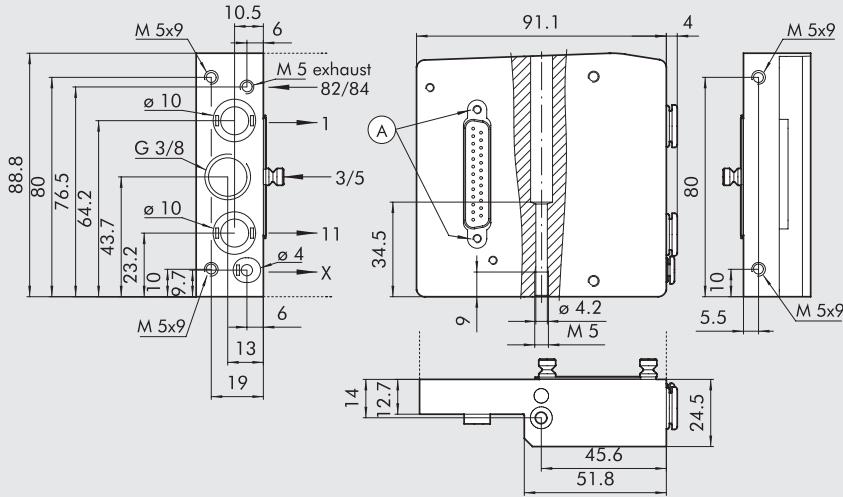

Code	Description	Weight [g]
0227301206	HDM 1-11 end-plate kit for B&R	340

**HDM 1 END-PLATE FOR B&R**

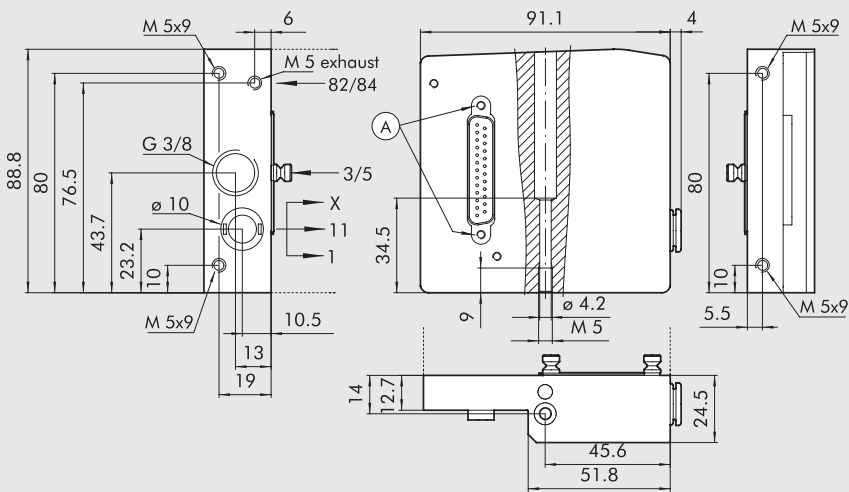

Code	Description	Weight [g]
0227301207	HDM 1 end-plate kit for B&R	380

**NOTES**

# HDM - VALVES, INTERMEDIATES ELEMENTS AND ACCESSORIES

HDM valve can be included in islands with any available input terminal. The same valve can be connected to the multiple connection end-plate and all the field bus end-plates.

**Note:** if you use valves 8S type or 10 exploiting their flow capacity, it is appropriate to choose the inlet end plate 1-11 type by feeding the pilots separately (to avoid the pressure to decrease too much on the pilots). If you use simultaneously more than one valve 8S or 10 it is necessary to potentiate the pneumatic feeding by inserting end plates having 12 mm pipe and/or through intermediate modules



VALVES

HDM - VALVES, INTERMEDIATES ELEMENTS AND ACCESSORIES

## MANUAL CONTROLS

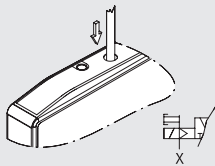

MONOSTABLE OVERRIDE PORT 2  
servo-assisted

- Press and hold the manual control in position (not necessary for bistable type K valve)
- Release the manual control:
  - The manual control returns to the home position.
  - Valves type I, W, L, V, F, and O reposition.
  - The type K valve remains switched

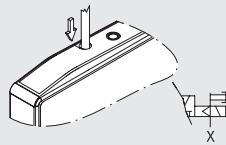

MONOSTABLE OVERRIDE PORT 4  
servo-assisted

- Press and hold the manual control in position (not necessary for bistable type K valve)
- Release the manual control:
  - The manual control returns to the home position.
  - Valves type I, W, L, V and F reposition.
  - The type K valve remains switched

With type F and V valves, this manual control is not present.

N.B.: The pilot power supply X must be present.

N.B.: The pilot power supply X must be present.

• The reference code for the monostable control ends in 0 (2 for type F).

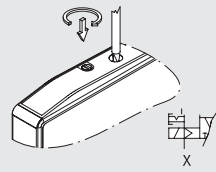
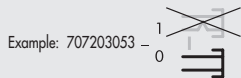

BISTABLE OVERRIDE PORT 2  
servo-assisted

- Press the manual control right in then turn it clockwise 90 degrees and Leave it in position.
- Rotate the manual control 90 degrees anticlockwise, and then release it.
  - The manual control returns to the home position.
  - Valves type I, W, L, V, F, and O reposition.
  - The type K valve remains switched

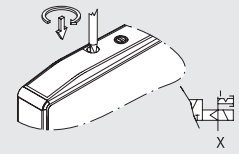

BISTABLE OVERRIDE PORT 4  
servo-assisted

- Press the manual control right in then turn it 90 degrees clockwise and Leave it in position.
- Rotate the manual control 90 degrees anticlockwise, and then release it:
  - The manual control returns to the home position.
  - Valves type I, W, L and O reposition.
  - The type K valve remains switched

With type F and V valves, this manual control is not present.

N.B.: The pilot power supply X must be present.

N.B.: The pilot power supply X must be present.

• The reference code for the monostable control ends in 1 (3 for type F).

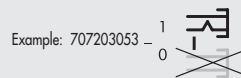

## 1 VALVE DIMENSIONS HDM Ø 4

\*uses a single PIN (like the V) and occupies 2 signals

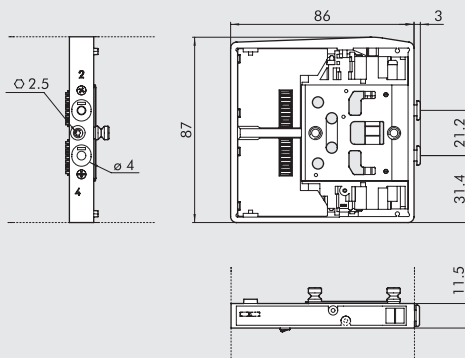

Symbol	Code	Manual control	Weight [g]
HDM I4	7071030530	monostable	130
	7071030531	bistable	
HDM W4	7071030630	monostable	130
	7071030631	bistable	
HDM L4	7071030730	monostable	130
	7071030731	bistable	
HDM V4	7071030130	monostable	115
	7071030131	bistable	
HDM *F4	7071030132	monostable	115
	7071030133	bistable	
HDM K4	7071030110	monostable	130
	7071030111	bistable	
HDM O4	7071030210	monostable	130
	7071030211	bistable	

**1 VALVE DIMENSIONS HDM Ø 6**

\*uses a single PIN (like the V) and occupies 2 signals

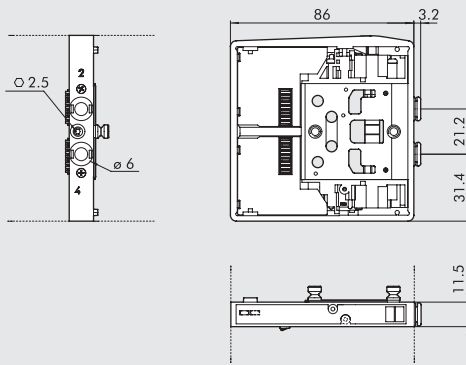

Symbol	Code	Manual control	Weight [g]
HDM I6	7072030530	monostable	130
	7072030531	bistable	
HDM W6	7072030630	monostable	130
	7072030631	bistable	
HDM L6	7072030730	monostable	130
	7072030731	bistable	
HDM V6	7072030130	monostable	115
	7072030131	bistable	
HDM *F6	7072030132	monostable	115
	7072030133	bistable	
HDM K6	7072030110	monostable	130
	7072030111	bistable	
HDM O6	7072030210	monostable	130
	7072030211	bistable	

**1 VALVE DIMENSIONS HDM Ø 8**

\*uses a single PIN (like the V) and occupies 2 signals

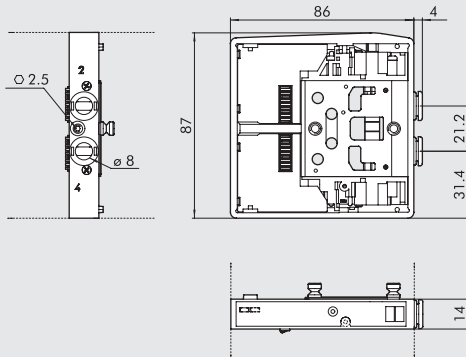

Symbol	Code	Manual control	Weight [g]
HDM I8	7073030530	monostable	140
	7073030531	bistable	
HDM W8	7073030630	monostable	140
	7073030631	bistable	
HDM L8	7073030730	monostable	140
	7073030731	bistable	
HDM V8	7073030130	monostable	130
	7073030131	bistable	
HDM *F8	7073030132	monostable	130
	7073030133	bistable	
HDM K8	7073030110	monostable	140
	7073030111	bistable	
HDM O8	7073030210	monostable	140
	7073030211	bistable	

**1 VALVE DIMENSIONS HDM Ø 8S**

\*uses a single PIN (like the V) and occupies 2 signals

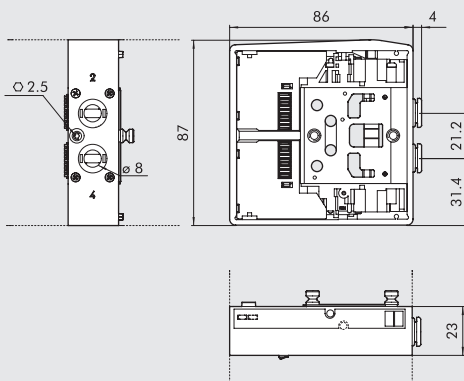

Symbol	Code	Manual control	Weight [g]
HDM I8S	7077030530	monostable	260
	7077030531	bistable	
HDM W8S	7077030630	monostable	260
	7077030631	bistable	
HDM L8S	7077030730	monostable	260
	7077030731	bistable	
HDM V8S	7077030130	monostable	241
	7077030131	bistable	
HDM *F8S	7077030132	monostable	241
	7077030133	bistable	
HDM K8S	7077030110	monostable	253
	7077030111	bistable	
HDM O8S	7077030210	monostable	262
	7077030211	bistable	

1 VALVE DIMENSIONS HDM Ø 10

\*uses a single PIN (like the V) and occupies 2 signals

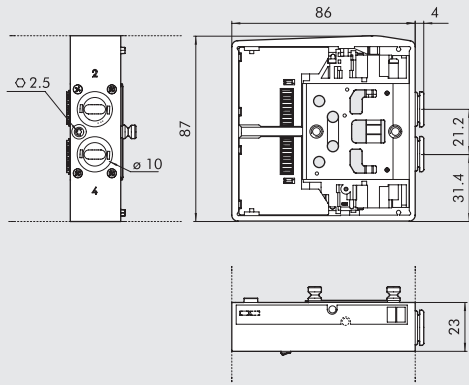

Symbol	Code	Manual control	Weight [g]
HDM I10	7078030530 7078030531	monostable bistable	250
HDM W10	7078030630 7078030631	monostable bistable	250
HDM L10	7078030730 7078030731	monostable bistable	250
HDM V10	7078030130 7078030131	monostable bistable	231
HDM *F10	7078030132 7078030133	monostable bistable	231
HDM K10	7078030110 7078030111	monostable bistable	243
HDM O10	7078030210 7078030211	monostable bistable	252

6 INTERMEDIATE THROUGH

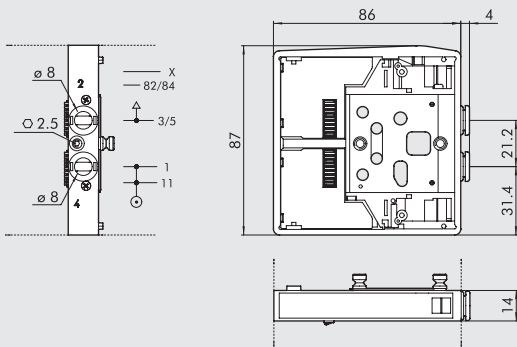

Code	Description	Weight [g]
0227301301	Intermediate through HDM	120

7 INTERMEDIATE BLIND

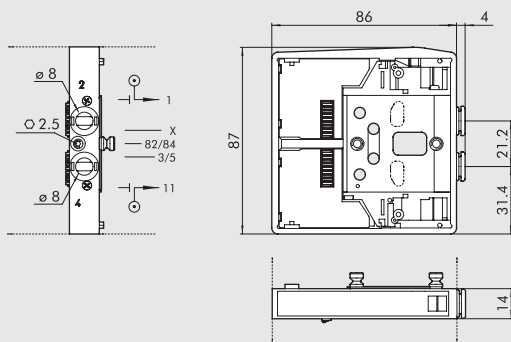

Code	Description	Weight [g]
0227301302	Intermediate blind HDM	117



## ACCESSORIES

### 16 CONNECTION BRACKETS ON DIN BAR

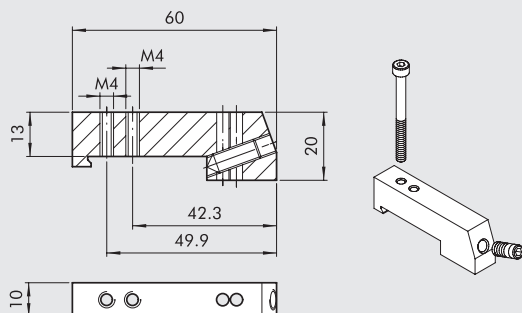

Code	Description	Weight [g]
0227301600	Connection brackets on din bar HDM/CM	30

Supplied complete with one M4x45 screws and one M6 grub screw  
Individually packed

### SILENCER FOR FITTING, Ø 8

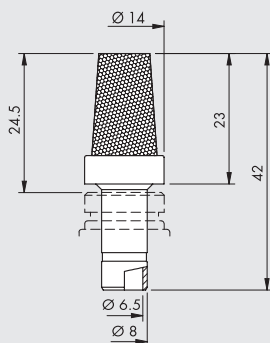

Code	Description	Flow rate at 6.3 bar [Nl/min]	Weight [g]
W0970530084	Silencer for fitting, Ø 8	2400	15

At the 3/5-exhaust port of the intermediate throughreference 6 and of the exhaust switch reference 20

### R17 - PIPE RELEASE SPANNER

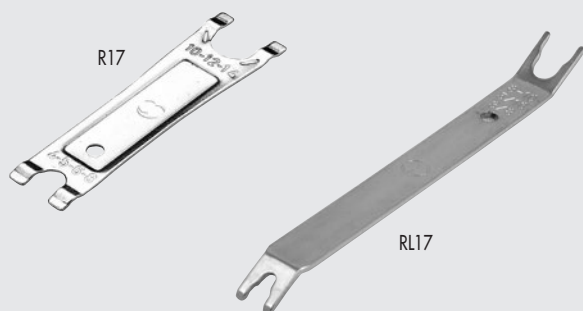

Code	Rif.	Length [mm]	Ø Tube
2L17001	RL17	140	from 3 to 10
2017001	R17	95	from 4 to 14

## SPARES

### GRUB SCREW KIT

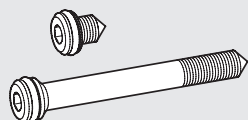

Code	Description
0227301800	Grub screw for Multimach HDM/CM

Comes in 1 + 1 pc. packs